

CORNER POST

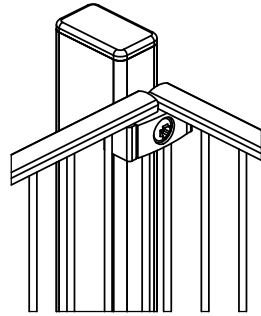

PANEL MOUNTING DETAIL

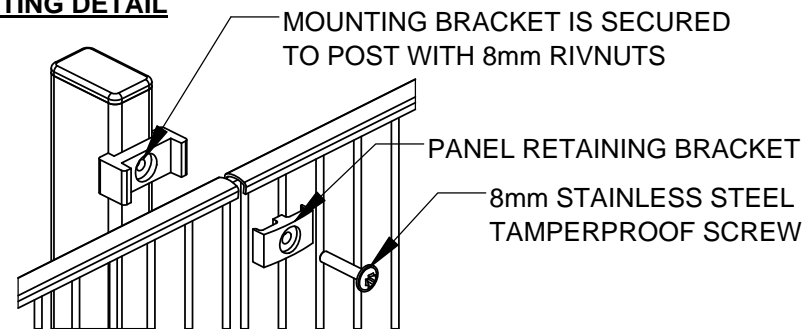

LINE POST

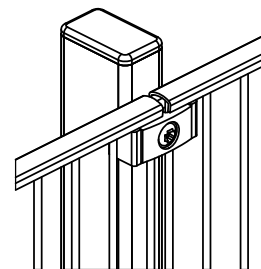

END POST

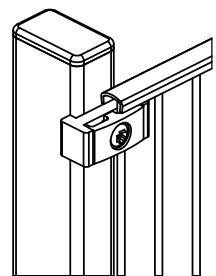

FLANGE MOUNT

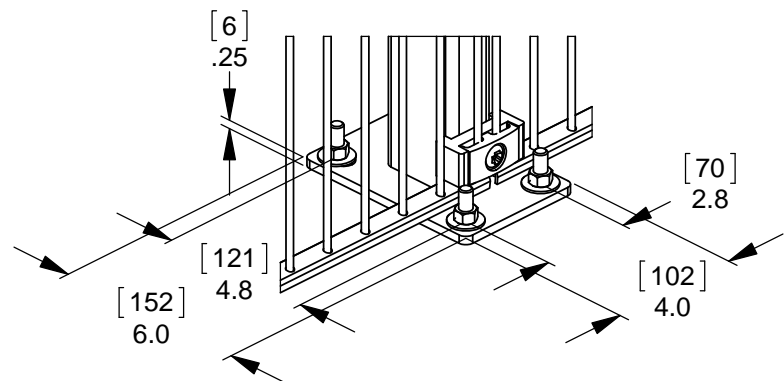

UNI-CHILD WELDED WIRE PANEL

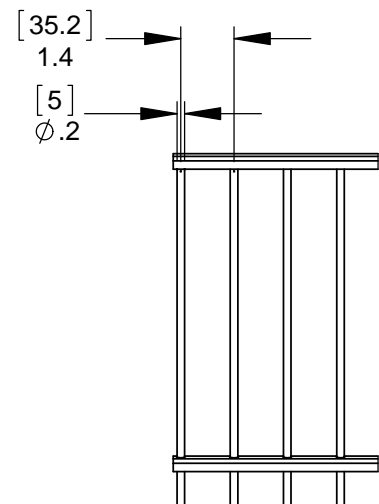
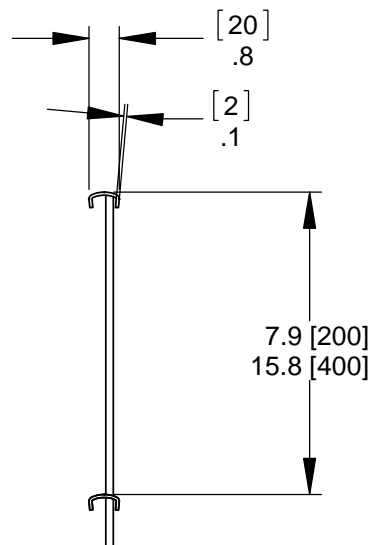

1.5 [38] x 2.5 [64] x .13 [3] HSS POST

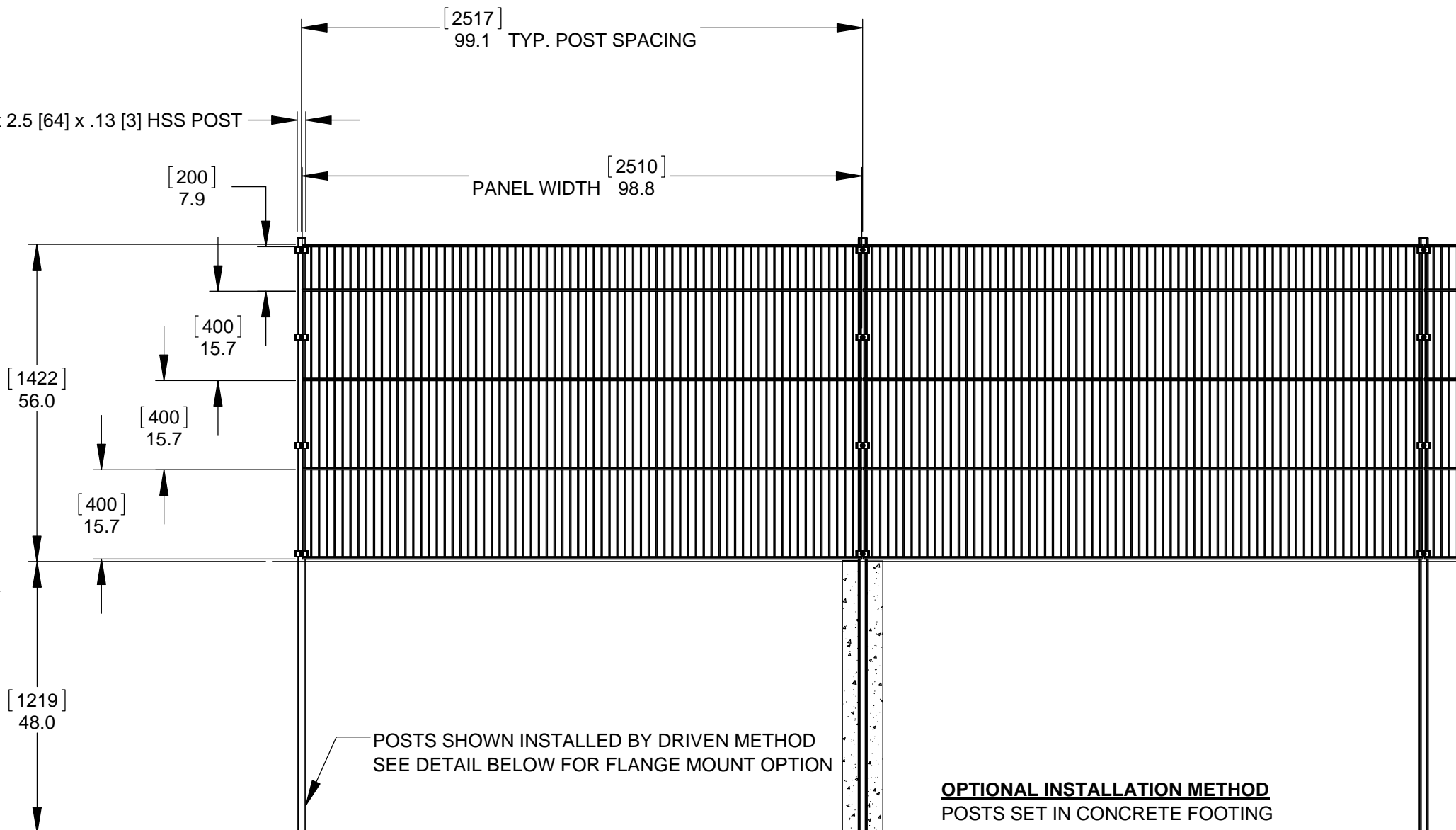

- NOTES:**
 FINISH:
 - GALVANIZED
 - BLACK POLYESTER POWDER COAT

Description:
4'-8" [1422mm] UNI CHILD WELDED WIRE FENCE
 1.5 [38] x 2.5 [64] RECTANGULAR POSTS



115 Lawson Crescent
 Winnipeg, Manitoba, Canada, R3P 1A6
 Phone: 1-866-300-1110
 Fax: 1-204-284-1868
 Web: www.wallaceintl.com

Customer / Project Name: -		Date: 1/26/2018
Drawing No. 4'-8" UNI CHILD		Rev. Sheet: 1 of 1