

CORNER POST

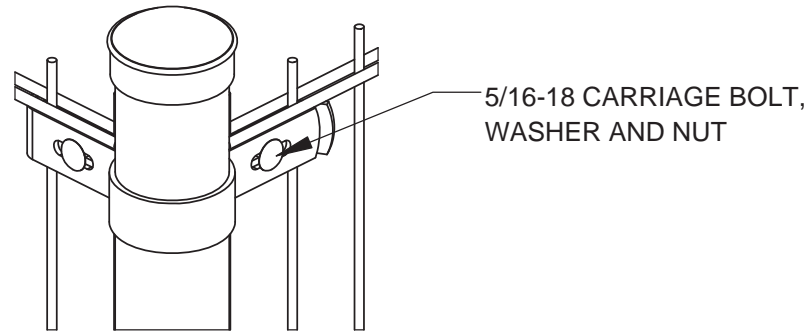

LINE POST

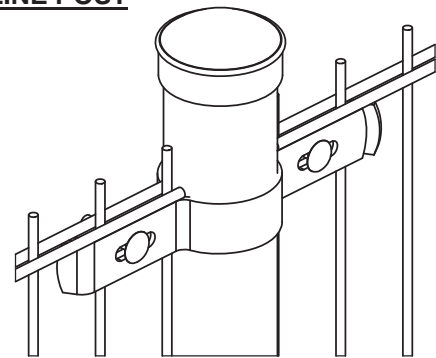

END POST

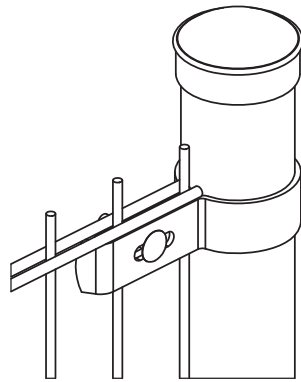

PALLAS LITE WELDED WIRE PANEL

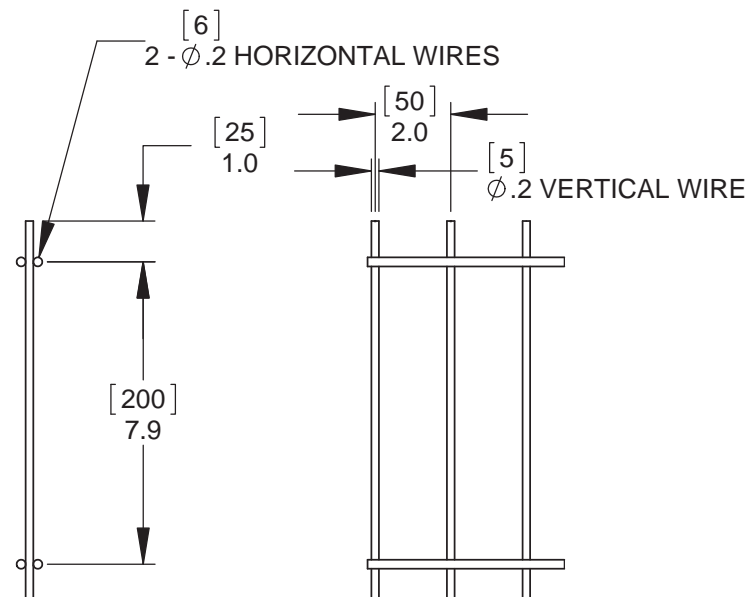

FLANGE MOUNT

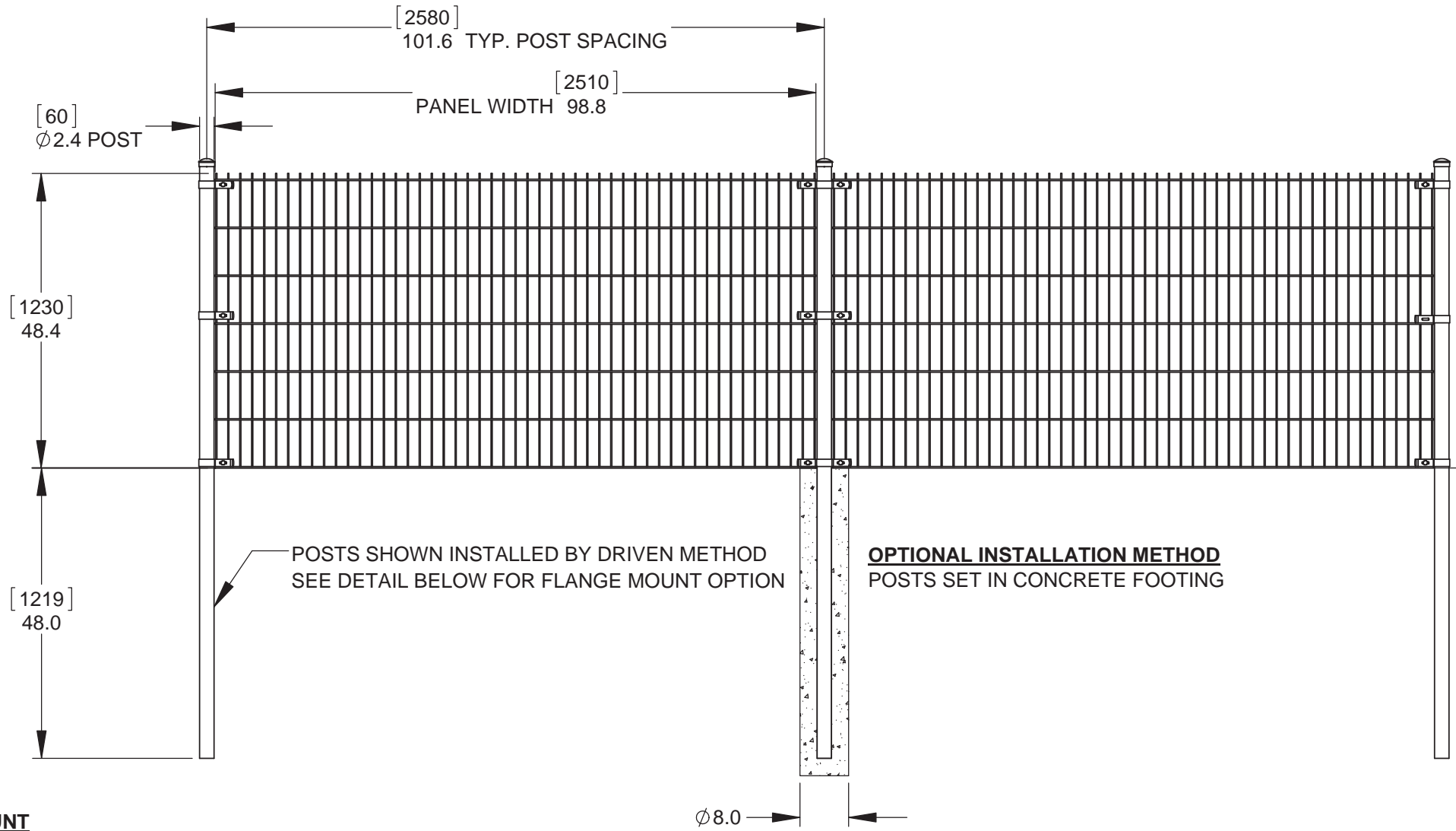
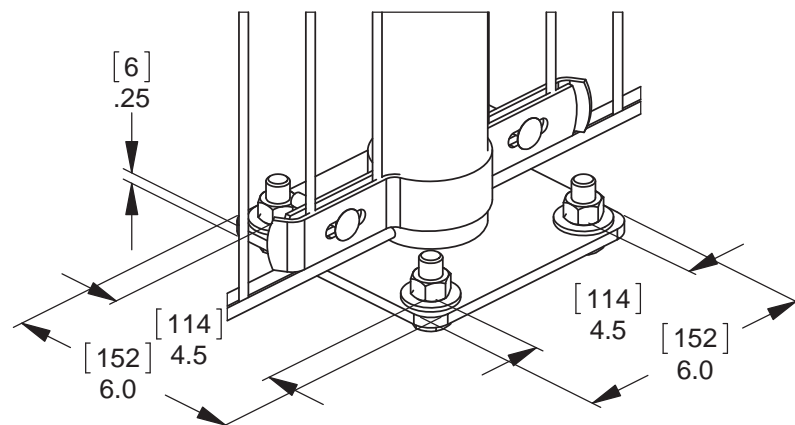

- NOTES:**
FINISH:
- GALVANIZED
- BLACK POLYESTER POWDER COAT



90 Lowson Crescent
Winnipeg, Manitoba, Canada, R3P 2H8
Phone: 1-866-300-1110
Fax: 1-204-284-1868
Web: www.wallaceperimetersecurity.com

Description:		4' [1.2M] PALLAS LITE WELDED WIRE FENCE	
Customer / Project Name:		-	
Finish:	SEE NOTES	Date:	6/26/2017
Drawing No.	4' PALLAS LITE	Rev.	Sheet:
			1 of 1