

CORNER POST

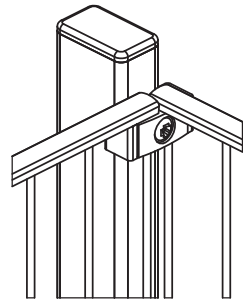

PANEL MOUNTING DETAIL

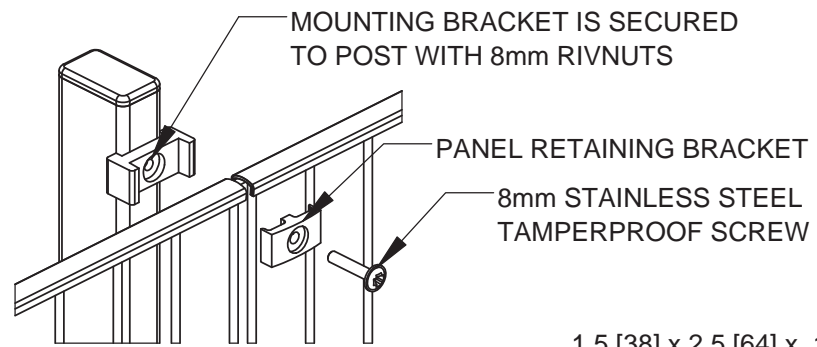

LINE POST

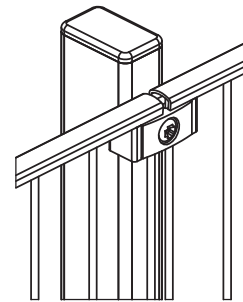

HEIGHT	QTY.
4' [1.2]	3
6' [1.8]	4
8' [2.4]	5

END POST

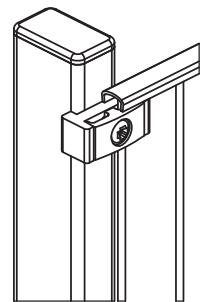

FLANGE MOUNT

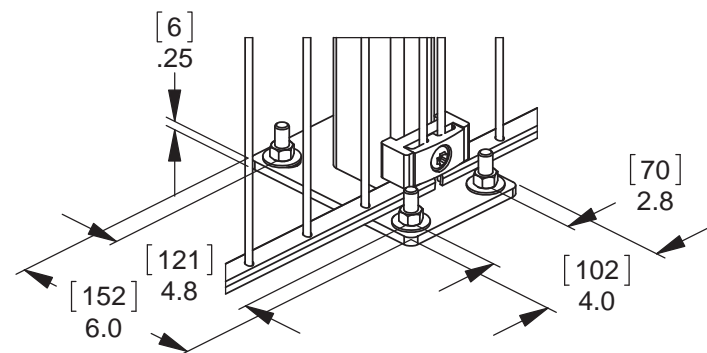

UNI WELDED WIRE PANEL

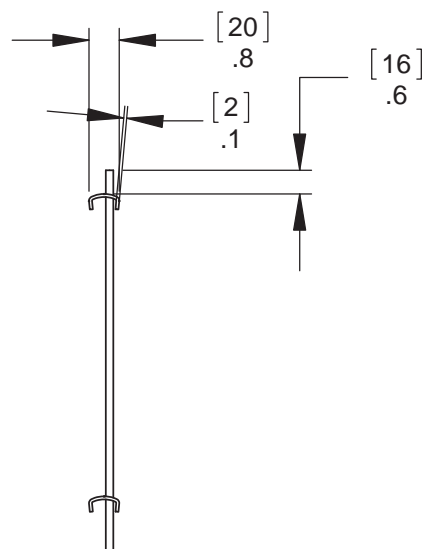

SERRATED TOP

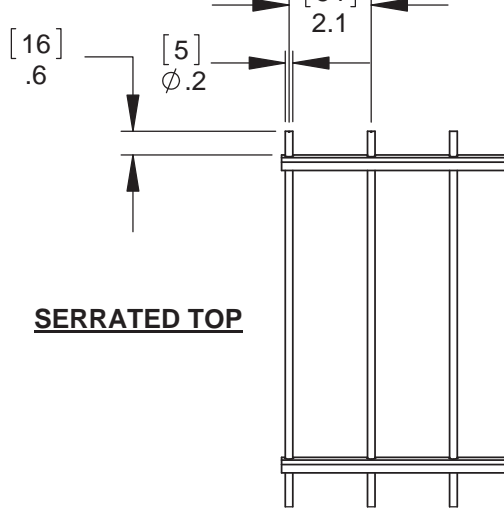

SMOOTH TOP

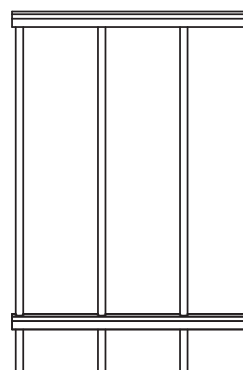

1.5 [38] x 2.5 [64] x .13 [3] HSS POST

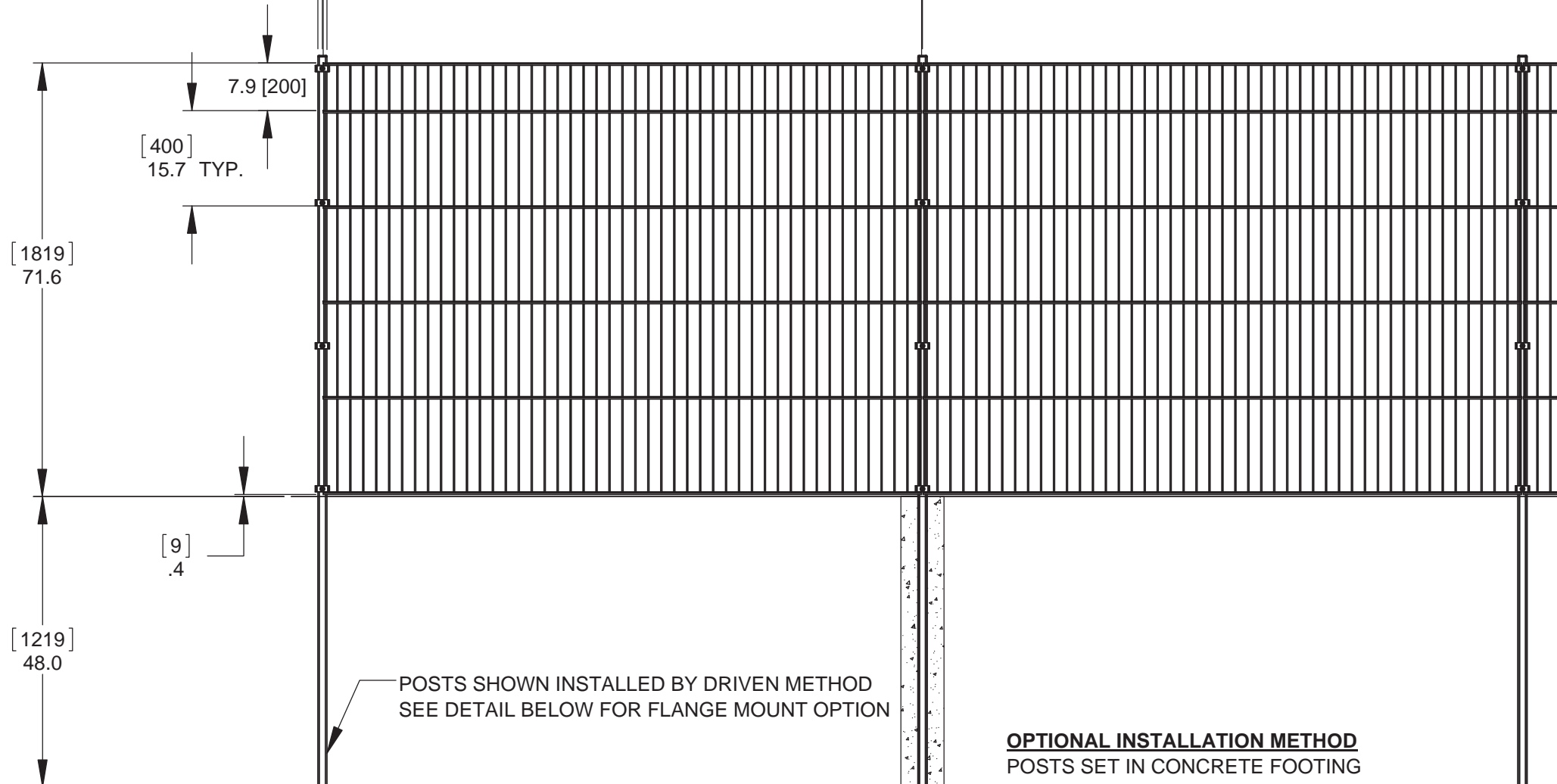

OPTIONAL INSTALLATION METHOD
POSTS SET IN CONCRETE FOOTING

- NOTES:**
 FINISH:
 - GALVANIZED
 - BLACK POLYESTER POWDER COAT



90 Lawson Crescent
 Winnipeg, Manitoba, Canada, R3P 2H8
 Phone: 1-866-300-1110
 Fax: 1-204-284-1868
 Web: www.wallaceintl.com

Description:		6' [1.8M] UNI WELDED WIRE FENCE	
		1.5 [38] x 2.5 [64] RECTANGULAR POSTS	
Customer / Project Name:			
-			
Finish:		Date:	
SEE NOTES		11/2/2017	
Drawing No.		Rev.	Sheet:
6' UNI			1 of 1