

**CORNER POST**

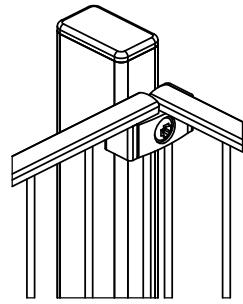

**PANEL MOUNTING DETAIL**

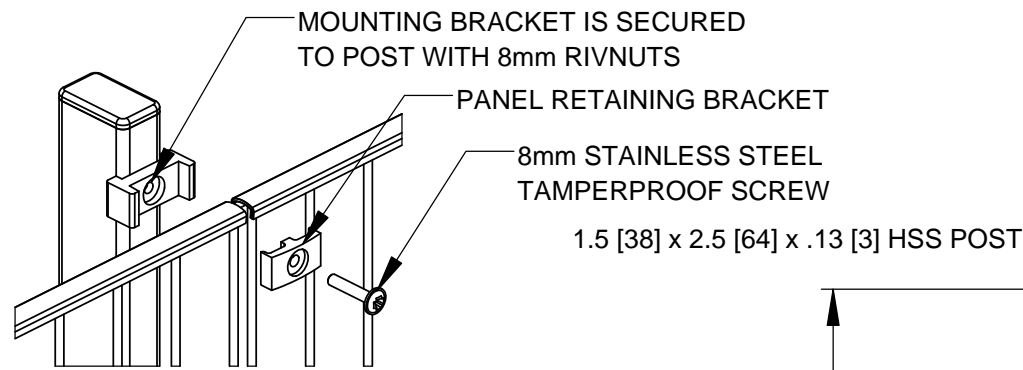

HEIGHT	QTY.
4' [1.2]	3
6' [1.8]	4
8' [2.4]	5

**LINE POST**

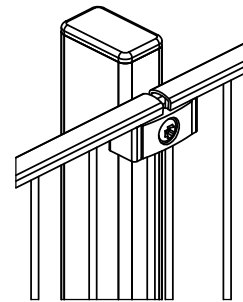

**END POST**

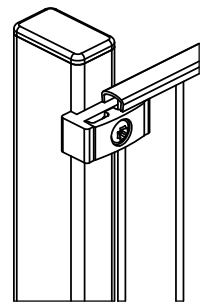

**FLANGE MOUNT**

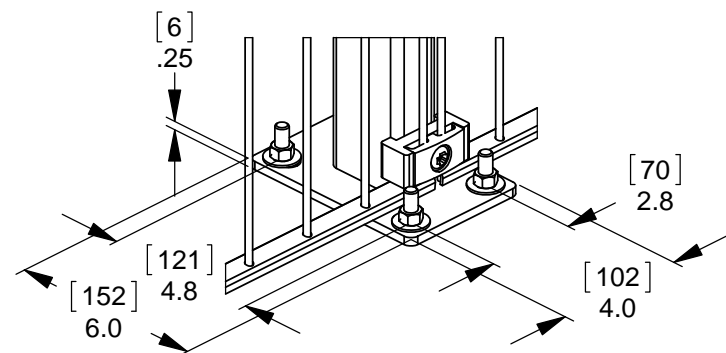

**UNI-MID WELDED WIRE PANEL**

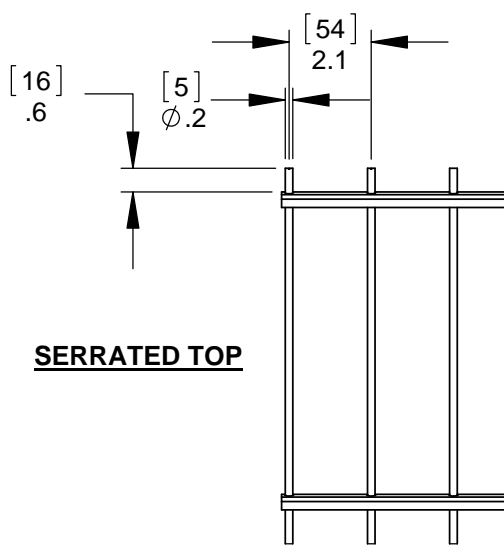
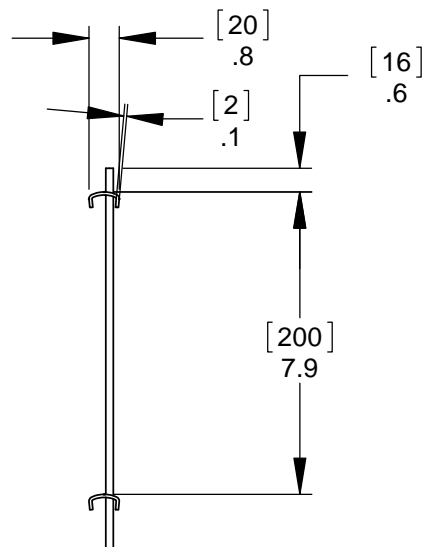

**SERRATED TOP**

**SMOOTH TOP**

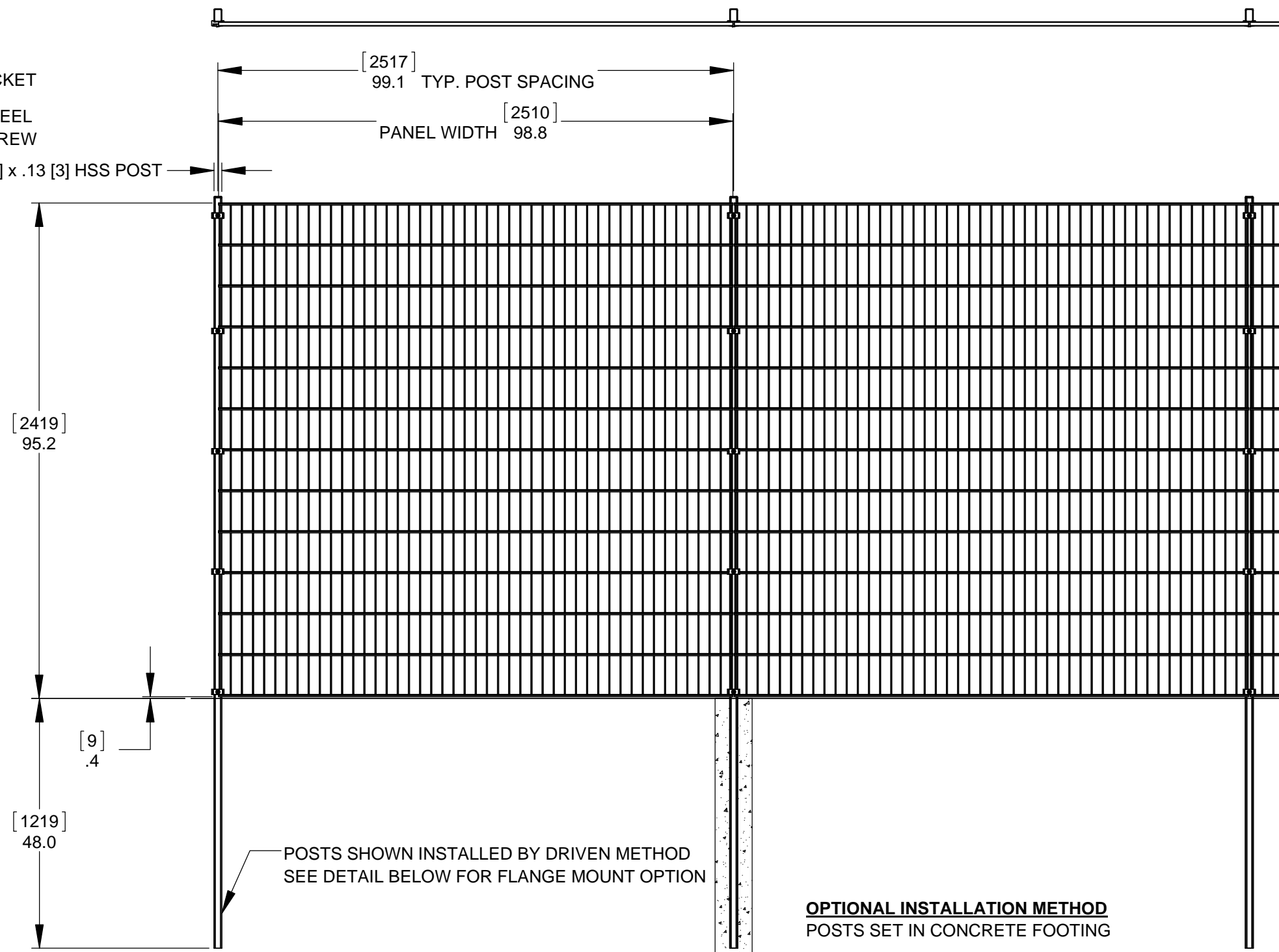
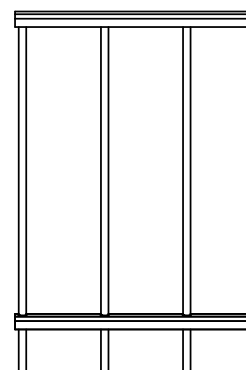

- NOTES:**  
 FINISH:  
 - GALVANIZED  
 - BLACK POLYESTER POWDER COAT

Description:		<b>8' [2.4M] UNI SECURITY WELDED WIRE FENCE</b>	
		1.5 [38] x 2.5 [64] RECTANGULAR POSTS	
Customer / Project Name:			
-			
Finish:		SEE NOTES	
Date:		10/4/2017	
Drawing No.		Rev.	
<b>8' UNI SECURITY</b>			
Sheet:		1 of 1	

90 Lowson Crescent  
 Winnipeg, Manitoba, Canada, R3P 2H8  
 Phone: 1-866-300-1110  
 Fax: 1-204-284-1868  
 Web: www.wallaceintl.com