

RAMPART 358 WELDED WIRE

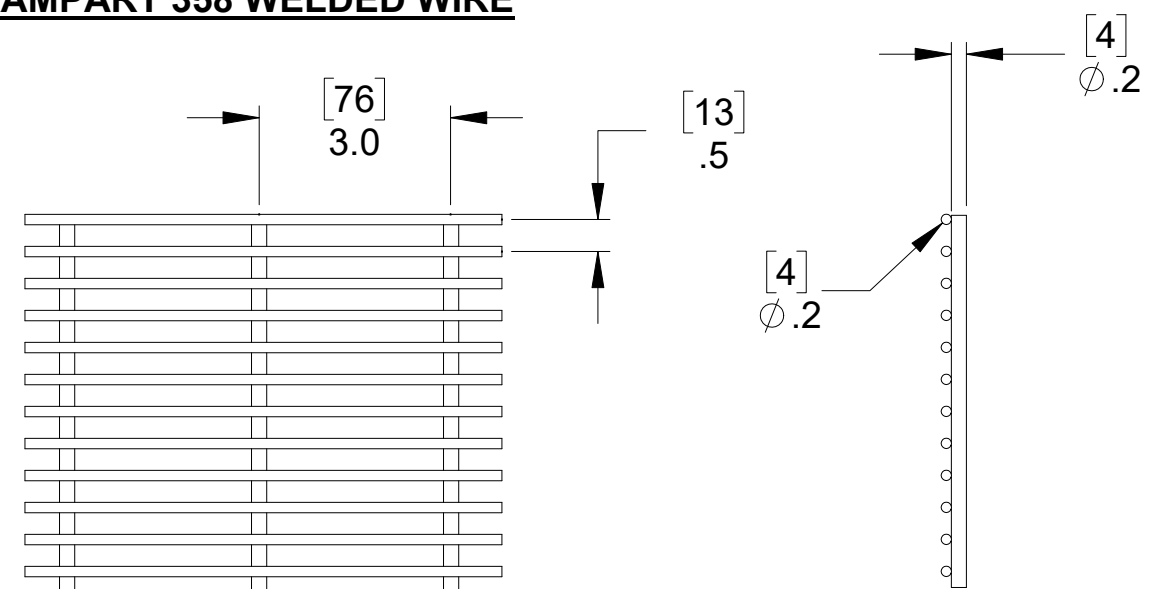

TYPICAL CORNER POST INSTALLATION DETAIL

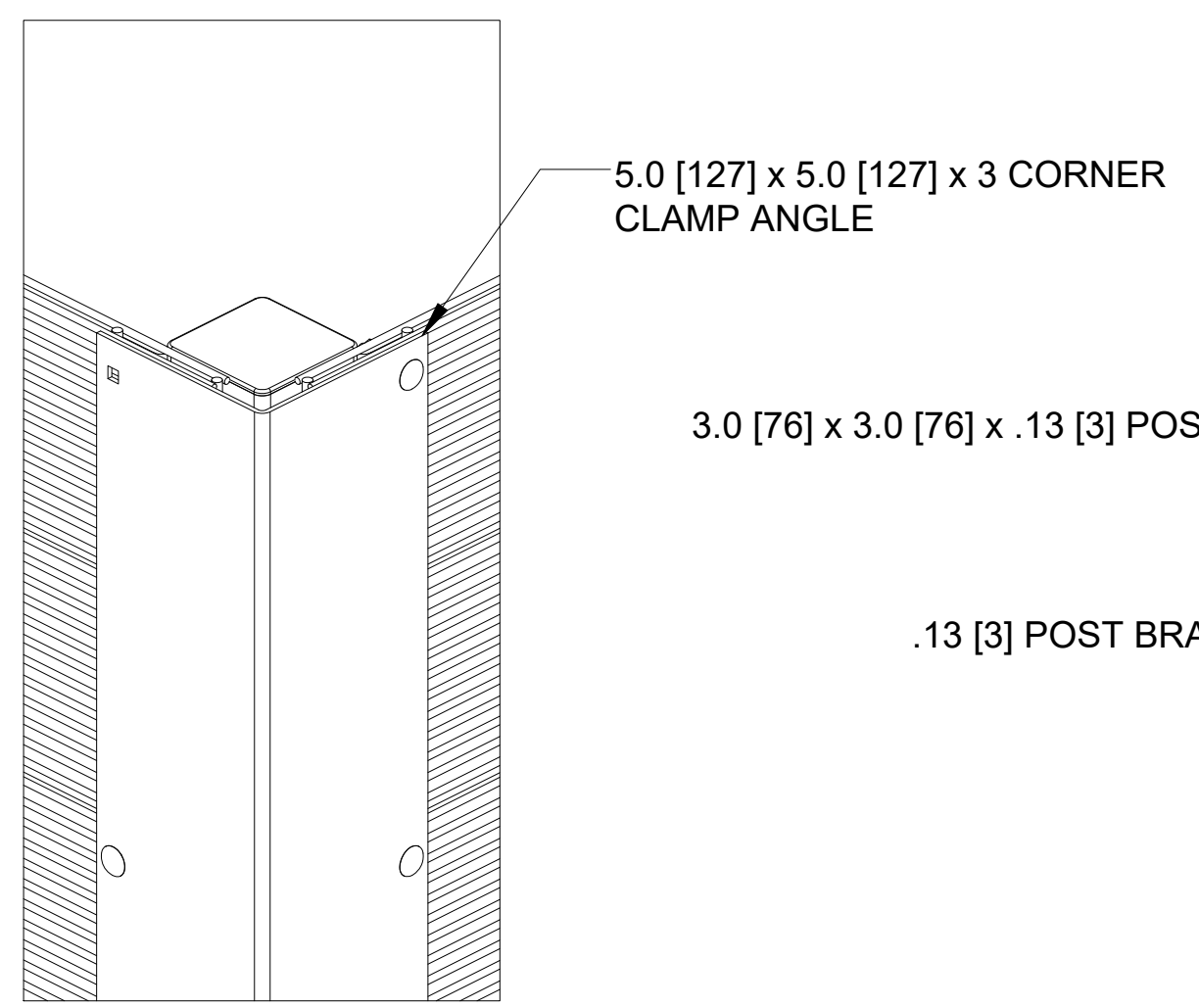
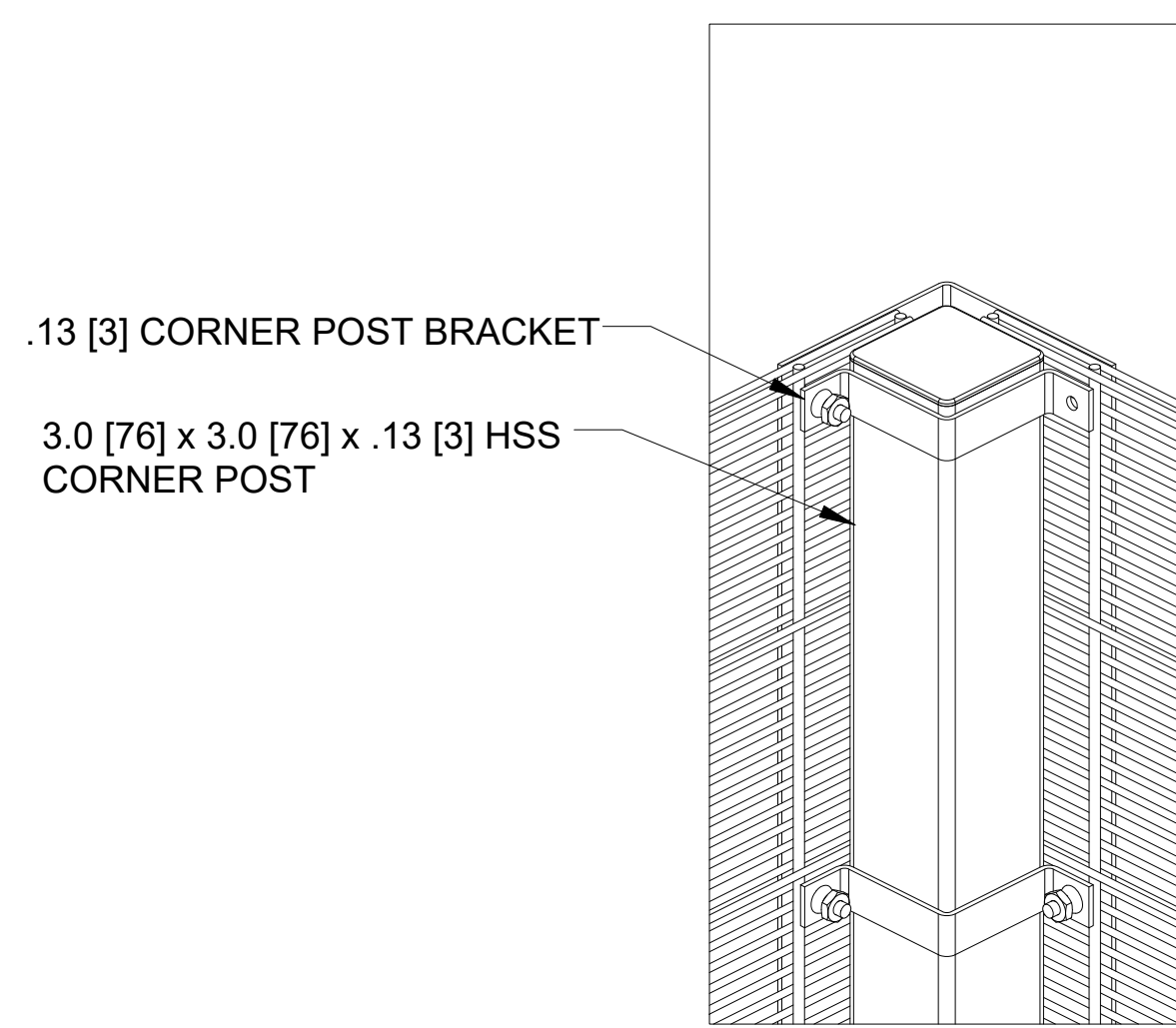

TYPICAL LINE POST / END POST INSTALLATION DETAIL

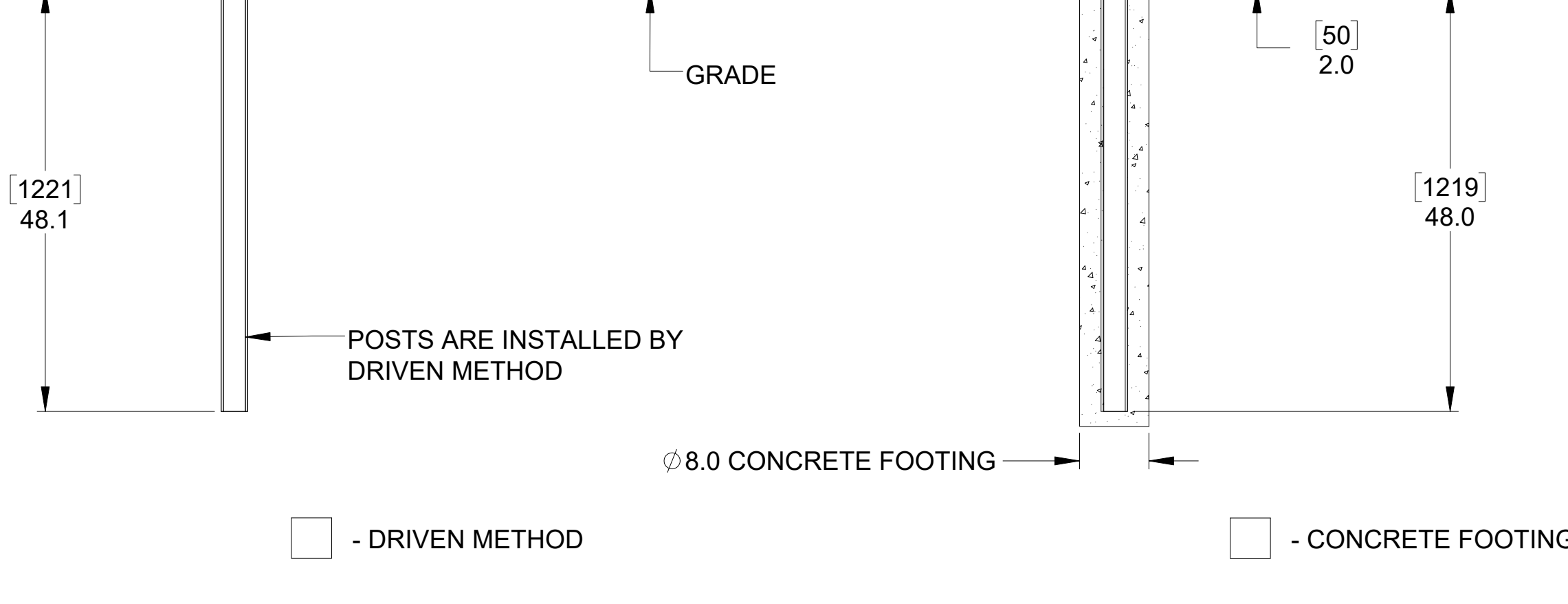
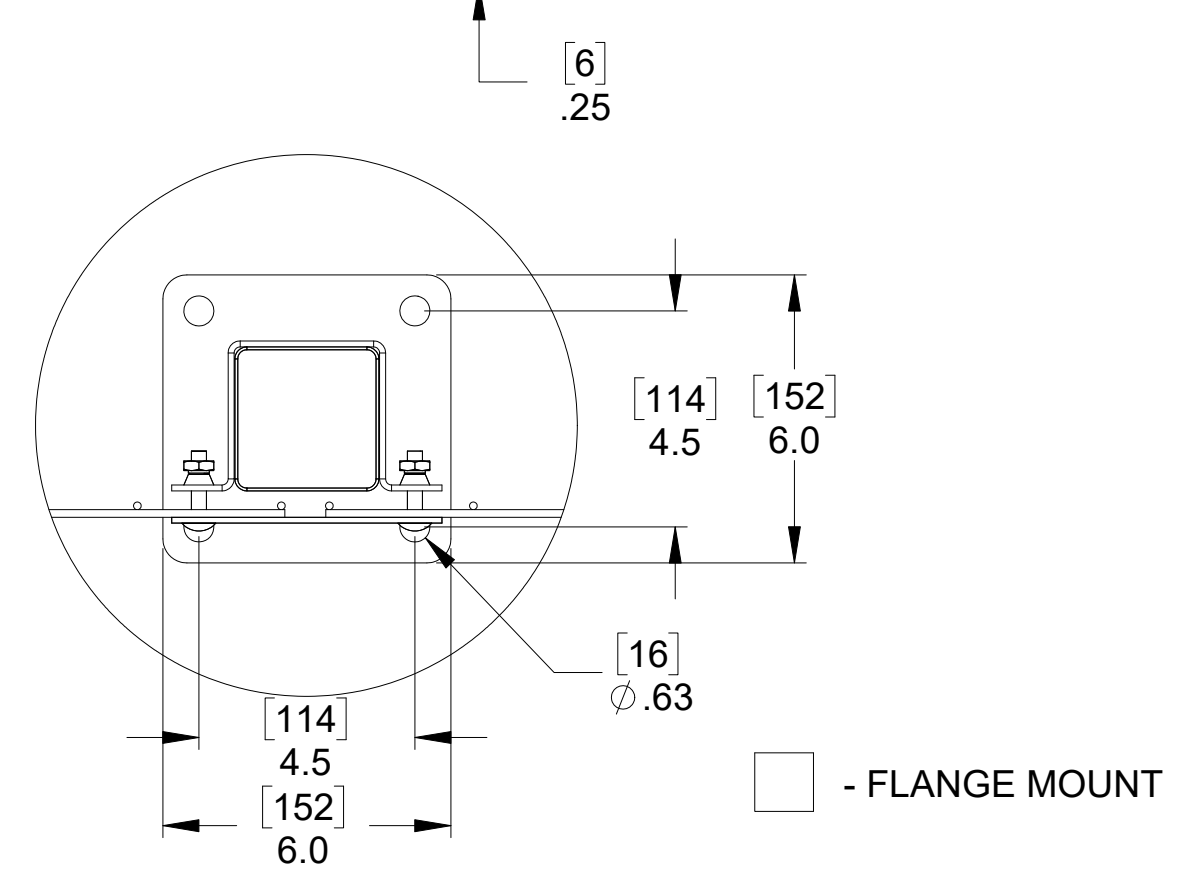
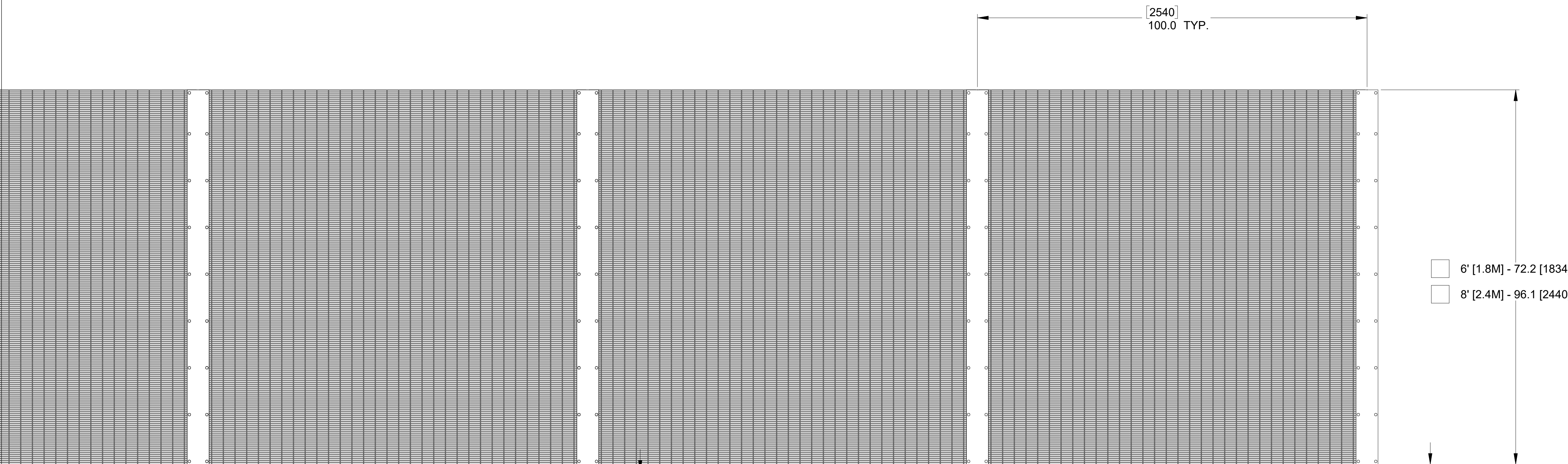
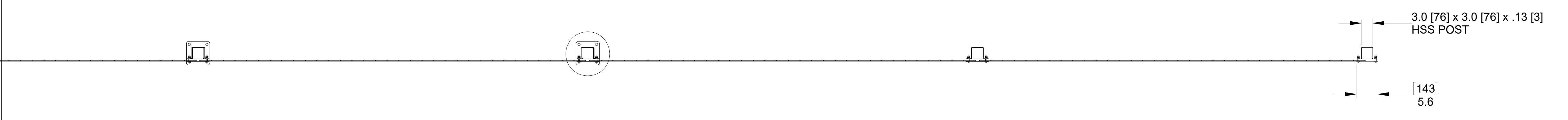
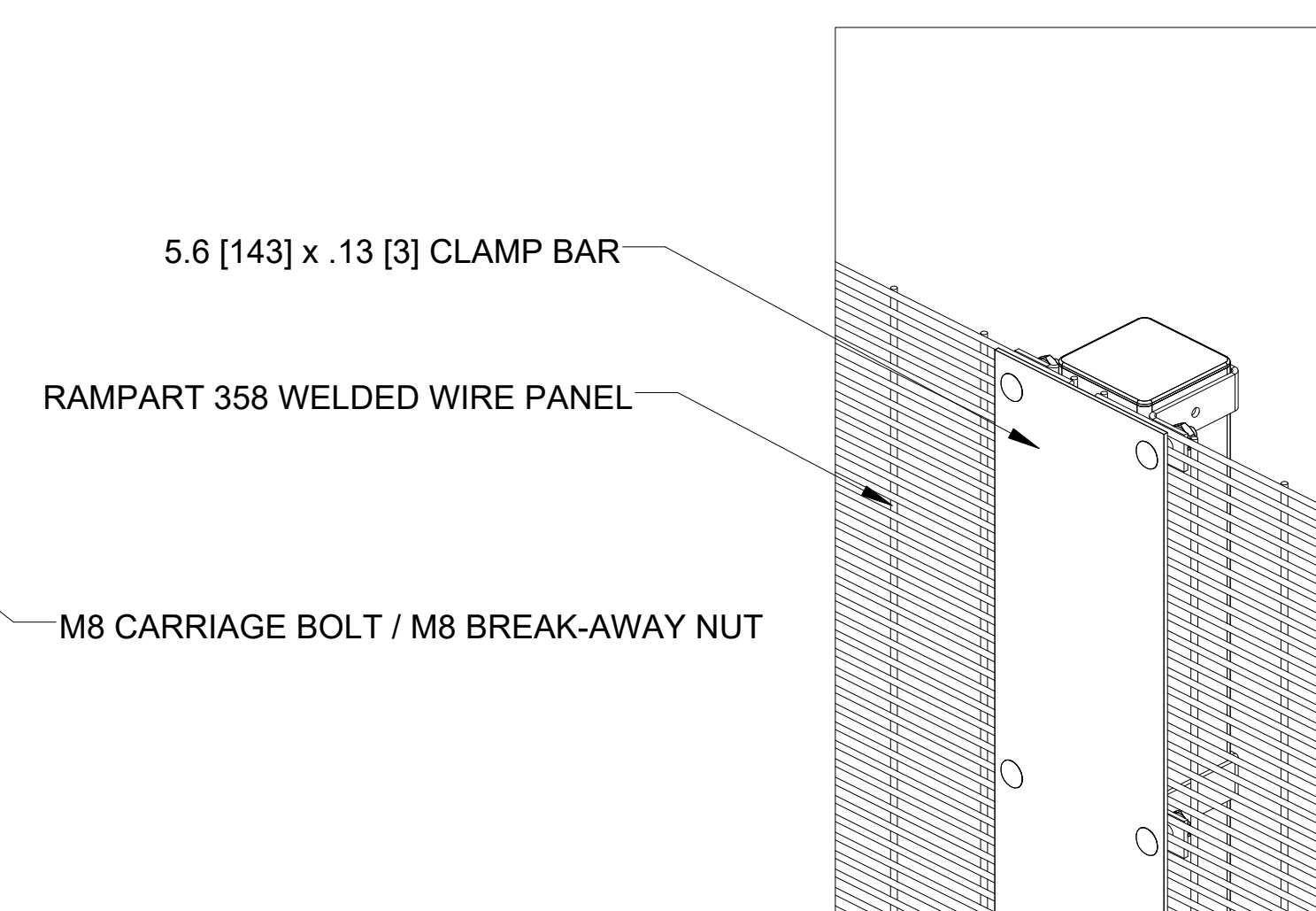
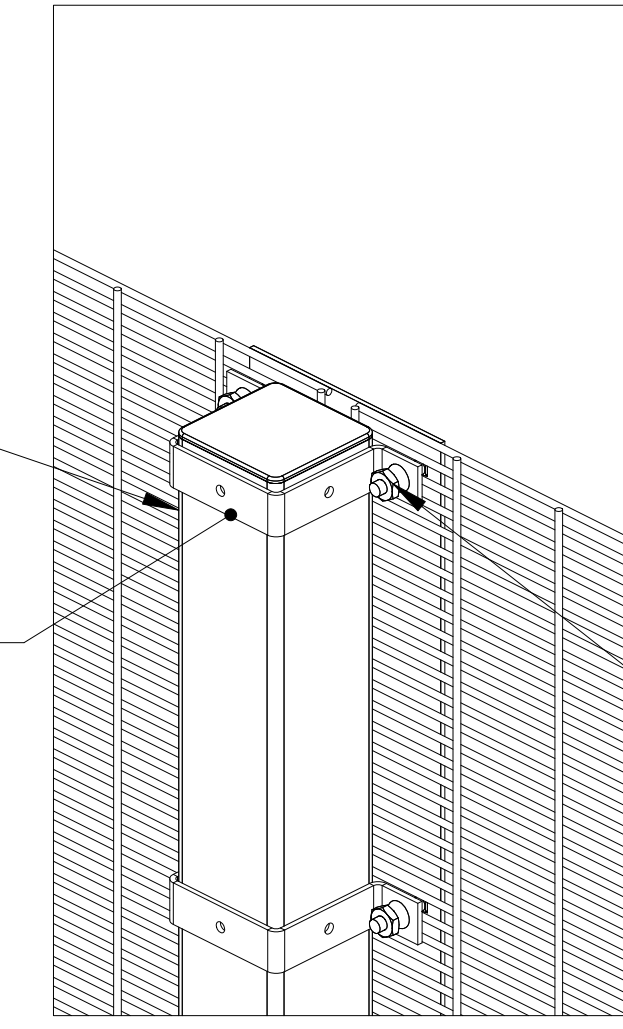

MOUNTING BRACKET QUANTITY

SIZE	QTY
6' [1.8]	7
8' [2.4]	9

NOTE:
DRAWING IS IN INCHES DIMENSIONS SHOWN IN [] ARE IN MILLIMETERS UNLESS OTHERWISE NOTED.

- FLANGE MOUNT

- DRIVEN METHOD

- CONCRETE FOOTING