



## SOP 6-1: How to Install Sensing Edges

USERS OF THIS SOP: WPS Certified Technicians and Qualified Contractors

APPLIES TO: FoldSmart Model and SpeedGate Gen II Model – PDTT Series or PDXT-C Series

Sensing edges (edge sensors) are CONTACT safety devices installed on automatic gates at potential crushing or shearing points.

The ends of the outermost gate panel sections (where the risk of entrapment or obstruction exists) include a provision for fitting contact-pressure-sensitive gate edges for connection to the control circuit. When installed sensing edges are pushed, they transmit a signal to the gate to stop and react in accordance with UL 325 regulations.

Sensing edges or photo eyes or a combination of both devices must be installed to protect against pedestrian entrapment in BOTH directions of the gate travel and where an entrapment hazard exists. The preferred external entrapment solution for bi-fold gates is a photo eye (i.e., Type B1 – non-contact) for the close direction and/or a hard-wired sensing edge (i.e., Type B2 – CONTACT) on the leading edge of the gate, which protects for both directions of gate travel.

In a single bi-fold gate there will be a total of one vertical and two horizontal sensing edge sections. In a double bi-fold gate there will be a total of two vertical and four horizontal sensing edge sections.

Leading edges (vertical) should be programmed to operate when the gate is moving in the CLOSE direction. Horizontal edges should be programmed to operate when the gate is moving in the OPEN direction.

Your Wallace Perimeter Security (WPS) bi-fold gate uses SENTIR Safety Contact Edges by ASO Safety Solutions with MILLER EDGE Multi-Input Modules. **NOTE: The following parts from WPS are subject to change.**

WPS Part Number	Description
100543	Sensing Edge - SENTIR 5ft Contact Edge, with Mounting Channel, Attachment and Resistor Set, and Link Kit
100537	ASO-1502-0430 – SENTIR Edge 25.30 TT Contact Profile with length: 25m (82ft), priced per foot

Mfg. Part Number	Description	Quantities
100904	MILLER EDGE Multi-Input Module The Solution – MIM-62	WPS supplies 1 multi-input module when 6 sensing edges are ordered (PDXT/PDPTT SpeedGate models).  WPS supplies 2 multi-input modules when 6 sensing edges are ordered (FoldSmart gate models).

**NOTE:** UL325 standard requires gate operators to monitor the presence of all external entrapment sensors, including non-contact (Photo Eyes) and contact (Edge) sensors. Your WPS gate operator monitors all external entrapment sensors connections by looking for Normally Closed (NC) contacts connected to input terminals.

Tools Required	
Impact Drill	Drill with Vari-Bit for knocking out conduit holes
Phillips-Head Screwdriver	Appropriate Conduit or Cabling Connectors
Wire Strippers	Soapy Water for lubricating gate edge rubber inserts
Fish Tape	Electrical Tape

## STEP ONE: Install Resistive (8.2 kΩ terminating resistor) Sensing Edges onto Gate Panels



For UL 325 compliance, all external entrapment protection sensors must have NC sensor outputs for monitoring and powering purposes.



The process for installing the resistive sensing edges is described below.

The 8.2 kΩ output goes dead short (closed circuit) when activated. However, for UL compliance control electronics must output a Normally Closed (NC) contact or voltage signal to the gate controller. To fulfill this requirement, the MIM-62 output interface includes an NC relay contact setting that opens when the 8.2 kΩ terminating resistor goes dead short. (The MIM-62 multi-input module, designed for 10 kΩ sensing edge termination, works effectively with 8.2 kΩ termination.)



**WARNING:** Deactivate gate during installation.



**REFER TO DIAGRAMS COMMENCING ON PAGE 4 FOR ADDITIONAL DETAILS.**

1. The sensing edges generally consist of 1 gate edge rubber section. Along with each rubber section there will be an accompanying aluminum channel section of the same length.

In a single bi-fold gate there will be a total of 1 vertical and 2 horizontal sections. In a double bi-fold gate there will be a total of 2 vertical and 4 horizontal sections.

2. Securely fasten the aluminum channel to the gate panel leading edge. Attach via self-tapping screw or drill and tap hole.
3. Drill a hole from the end of each side of the aluminum channel into the gate frame. This hole should be sized to permit cable to run through the gate frame.

4. Lubricate the edge outer lips with soap and water to allow the rubber edge to slide smoothly into the aluminum channel. When the water dries the edge will no longer slide.
5. There are two cabling formats for resistive edge - a resistive end and a cable end, or both cable ends (for connecting in series). **SERIES CONNECTIONS MUST NOT BE USED; DO NOT USE BOTH CABLE ENDS. EACH SENSING EDGE SECTION MUST HAVE A RESISTIVE END AND A CABLE END.**

Each resistive sensing edge will be independently connected to its own input on the MIM-62 Multi-Input Module. Up to 6 such inputs are provided on each module, with two Normally Closed (NC) output relays. As shown in the connection diagrams, one relay connects to edge inputs programmed at the gate controller to operate in the gate CLOSE direction. The other relay connects to edge inputs programmed to operate in the gate OPEN direction.

Once the edge has been slid into the aluminum channel, each end that has a wire pigtail (i.e., the cable end) must be fed into the hole that was drilled into the aluminum channel and gate frame and run back to the MIM-62 module.

6. Follow steps in sections **TWO, THREE and FOUR**: Connect sensing edge leads to the Multi-Input Module (MIM-62) and controller, and program the gate controller.

Section in this Document	Gate Model	Page Link
STEP TWO: Connecting the Sensing Edge Leads from Each Panel to the MIM-62 and Controller	SpeedGate	9
	FoldSmart	19
STEP THREE: Programming the Operator (Controller) Installer Menu to Accept Sensing Edge Inputs	SpeedGate*	25
	FoldSmart	26
STEP FOUR: Perform Sensing Edge Gate Tests	FoldSmart & SpeedGate	36

**\*NOTE:** SpeedGate controllers are currently factory programmed to use sensing edge terminal 72 input for CLOSE direction operation, and terminal 85 input for the OPEN direction. **DO NOT PERFORM FIELD PROGRAMMING OR RETROFITS ON AN EXISTING MODEL YOURSELF. CALL WPS TECHNICAL SUPPORT AT 1-866-300-1110.**

**SENTIR SENSING EDGE  
INSTALL DETAILS: PDXT**

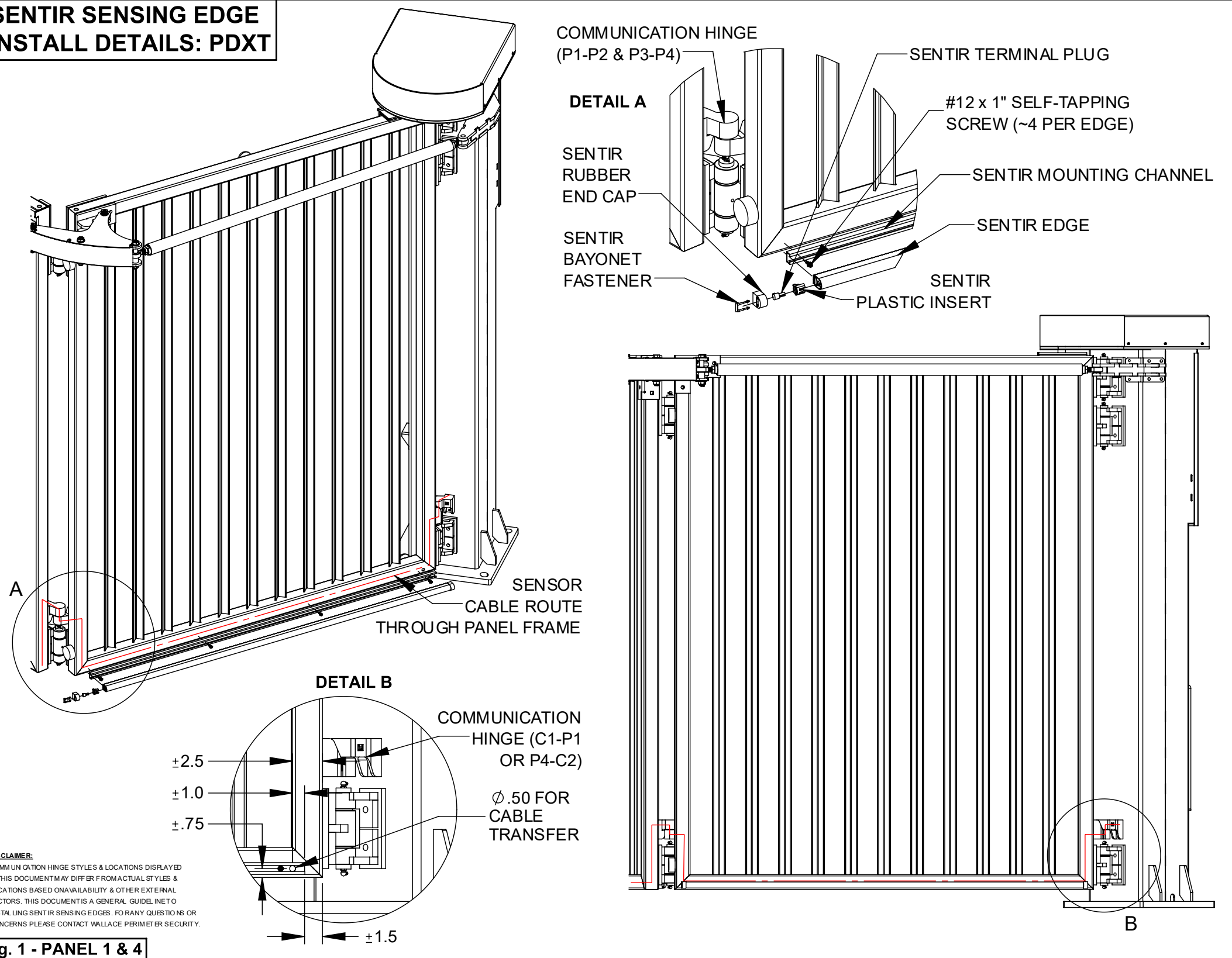

**DISCLAIMER:**  
COMMUNICATION HINGE STYLES & LOCATIONS DISPLAYED IN THIS DOCUMENT MAY DIFFER FROM ACTUAL STYLES & LOCATIONS BASED ON AVAILABILITY & OTHER EXTERNAL FACTORS. THIS DOCUMENT IS A GENERAL GUIDELINE TO INSTALLING SENTIR SENSING EDGES. FOR ANY QUESTIONS OR CONCERNS PLEASE CONTACT WALLACE PERIMETER SECURITY.

**Pg. 1 - PANEL 1 & 4**

**SPEEDGATE - PDXT**



**SENTIR SENSING EDGE  
INSTALL DETAILS: FSXT**

REFER TO SHIM INSTRUCTIONS FOLLOWING Pg. 2 - PANEL 2 & 3.

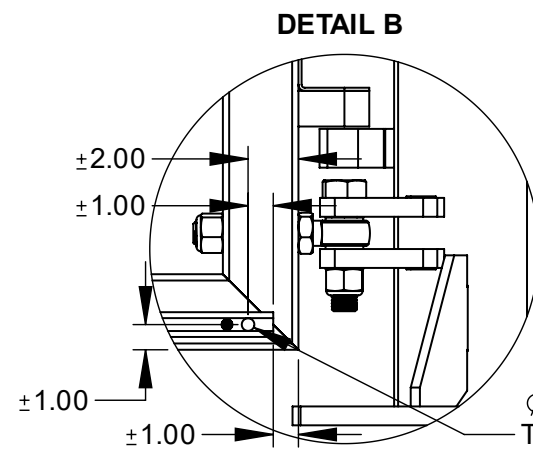
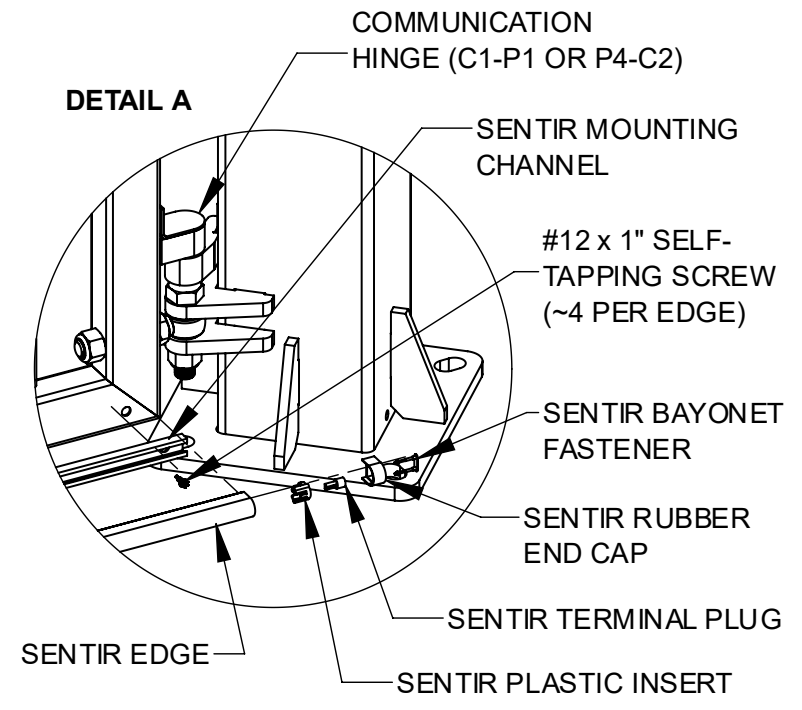
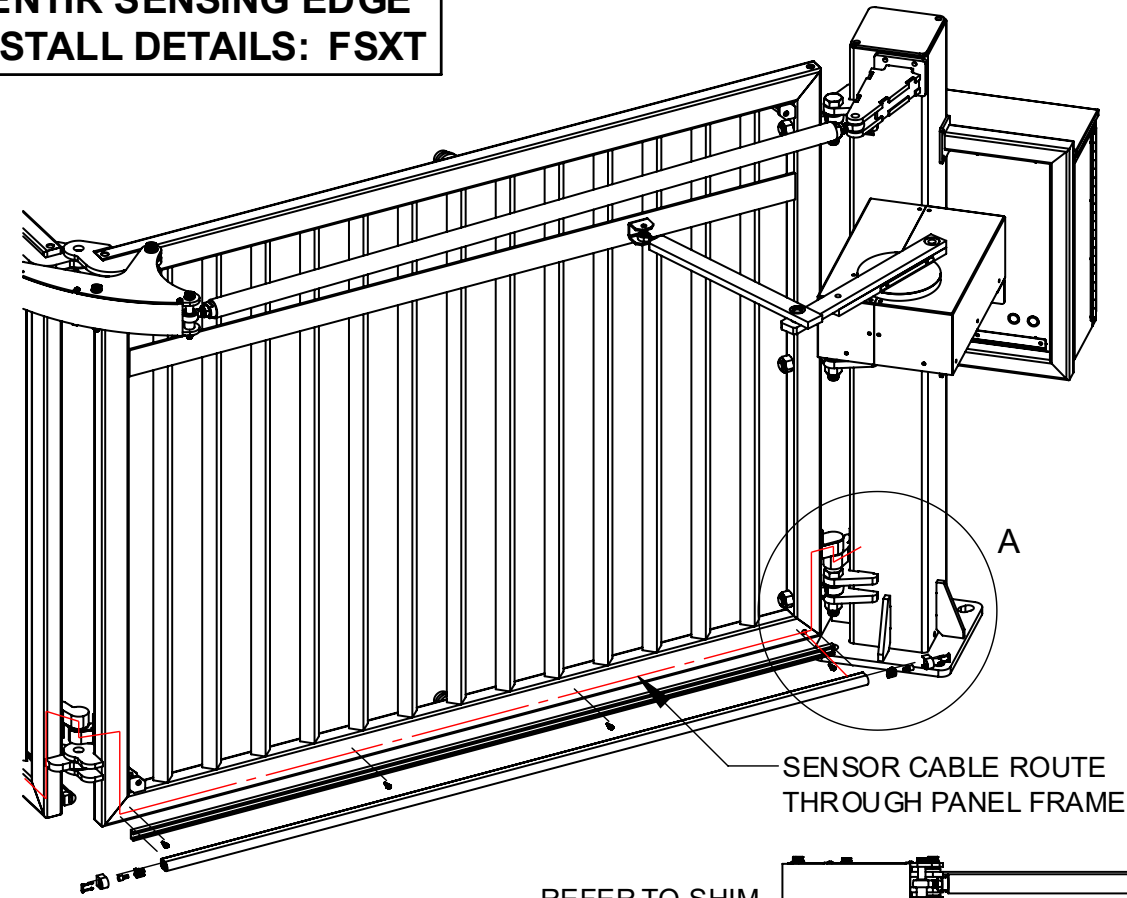

REFER TO SHIM INSTRUCTIONS FOLLOWING Pg. 2 - PANEL 2 & 3.

Ø .50 FOR CABLE TRANSFER

COMMUNICATION HINGE (P1-P2 & P3-P4)

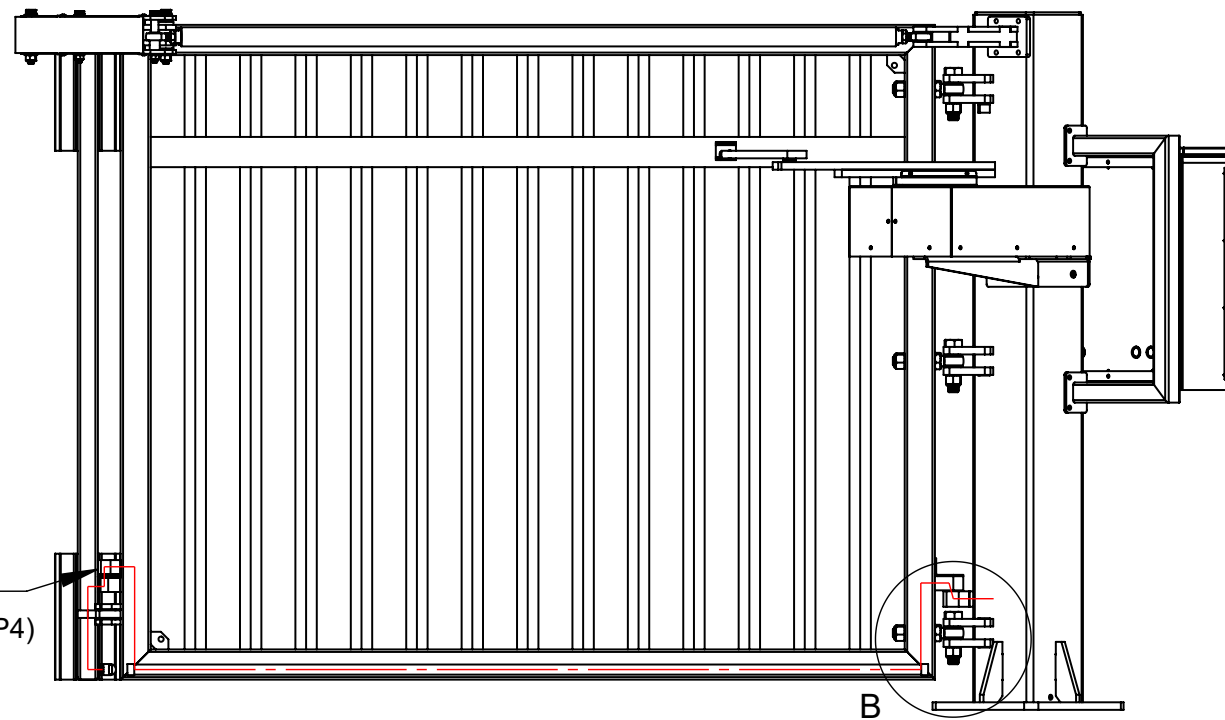

**DISCLAIMER:**  
COMMUNICATION HINGE STYLES & LOCATIONS DISPLAYED IN THIS DOCUMENT MAY DIFFER FROM ACTUAL STYLES & LOCATIONS BASED ON AVAILABILITY & OTHER EXTERNAL FACTORS. THIS DOCUMENT IS A GENERAL GUIDE TO INSTALL SENTIR SENSING EDGES. FOR ANY QUESTIONS OR CONCERNS PLEASE CONTACT WALLACE PERIMETER SECURITY.

**Pg. 1 - PANEL 1 & 4**



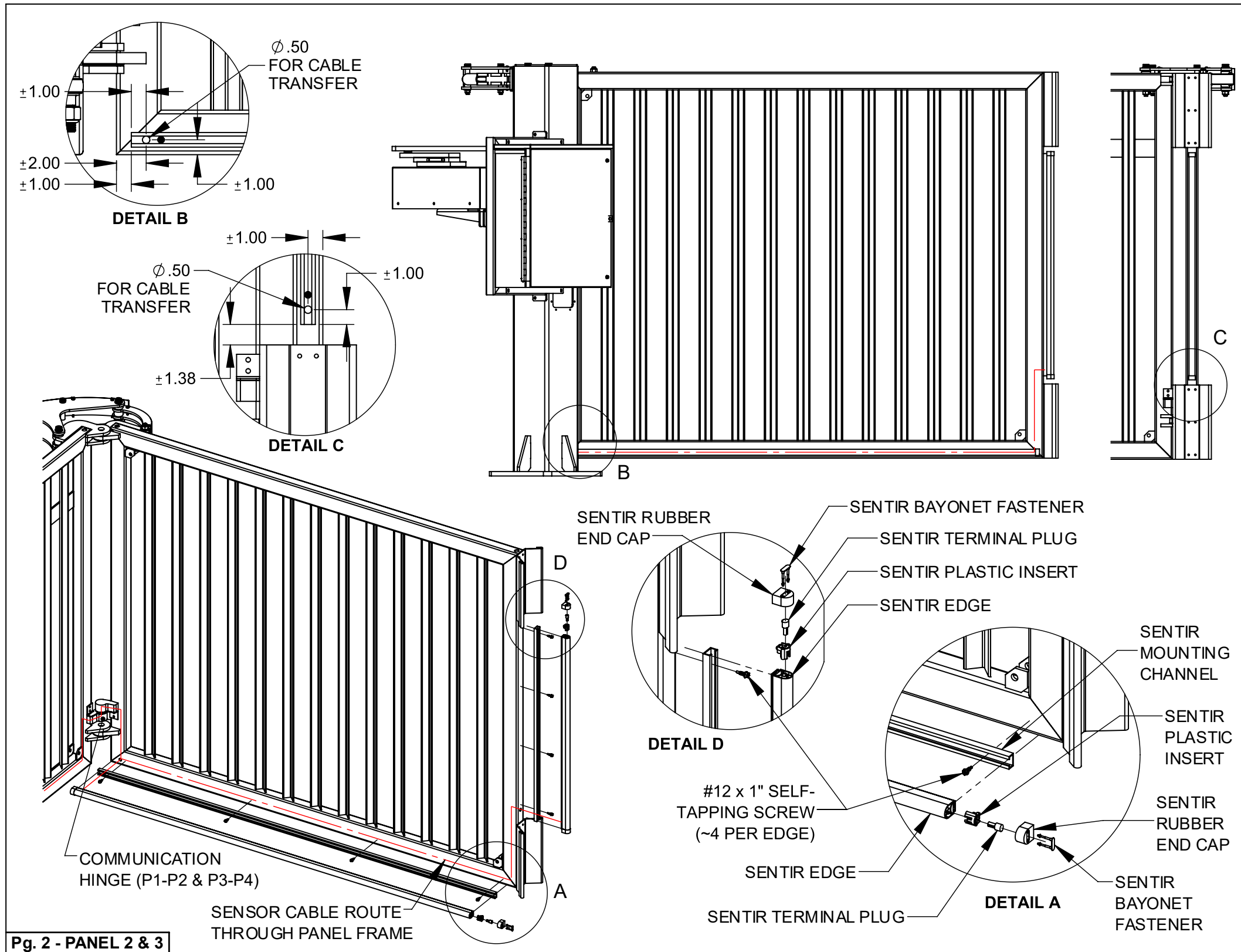

**SENTIR SENSING EDGE INSTALL DETAILS:  
INSTALL A SHIM, IF REQUIRED, FOR COMMUNICATION HINGE ALIGNMENT**

The communication hinge provides a secure pathway for the sensing edge cable. Occasionally, when the COLUMN-TO-PANEL hinges are adjusted out near maximum, the two halves of the communication hinge (i.e., pass-through hinge) will not align.

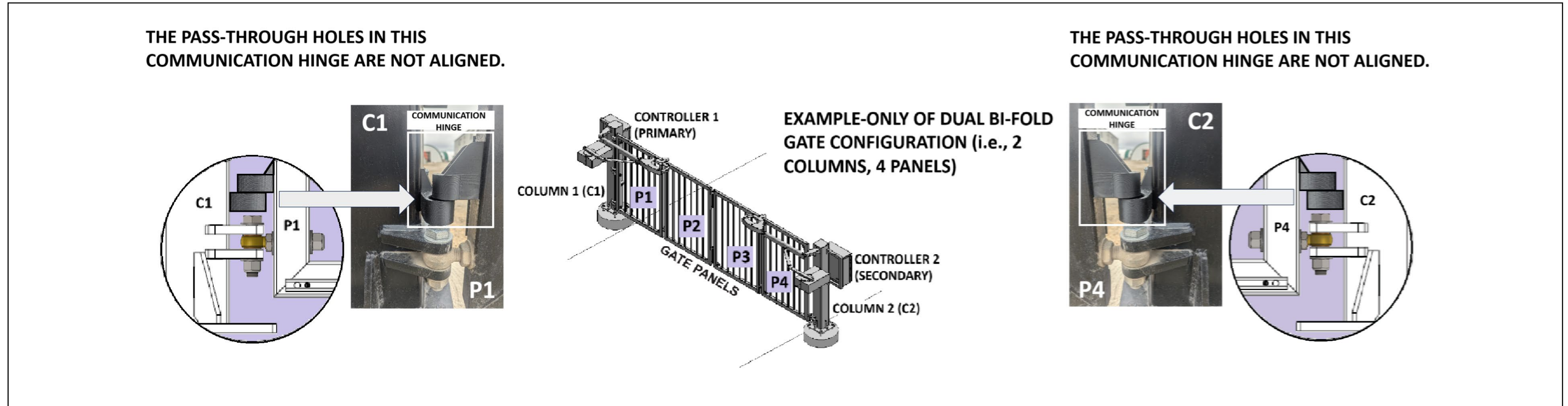

Communication hinge misalignment may occur at the two COLUMN-TO-PANEL points only. **Inspect each communication hinge at C1-P1 and C2-P4 for alignment.** To correct misalignment, WPS supplies two 1/4" and two 1/2" thick shims with the same mounting dimensions as the communication hinge bodies, with 1/4"-20 x 2.5" fasteners.

**IMPORTANT:** Maximum TWO shims per column. The same shim thickness does not need to be used at both columns. However, DO NOT install two 1/2" shims at one column. **If total misalignment is 1", this is indicative of a problem that needs to be addressed at a deeper level. Contact WPS Technical Support at 1-866-300-1110.**



**NOTE:** The communication hinge designed for column-to-panel installation differs from the panel-to-panel communication hinge type.



If required, install one or both shims behind the panel-side piece of the communication hinge, at C-1 P1. **The following instructions are also applicable to the C2-P4 side of your FoldSmart gate, as a “mirror image”.**

**TWO-PIECE COMMUNICATION HINGE FOR COLUMN-TO-PANEL** ✓

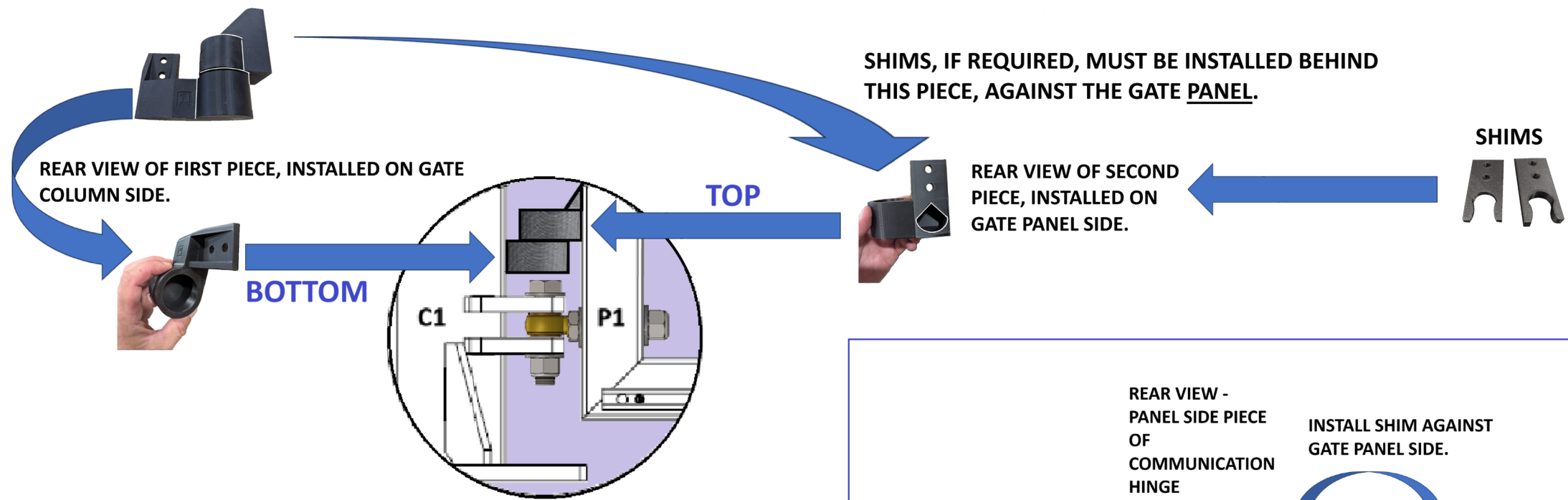

**OVERALL:**

- Maximum TWO shims per column.
- The same shim thickness does not need to be used at both columns.
- The maximum you can install is one 1/2" shim plus one 1/4" shim on each column (i.e., 3/4" per column).
- **DO NOT install two 1/2" shims on one column.** If total misalignment is 1", this is indicative of a problem that needs to be addressed at a deeper level. **Contact WPS Service Team at 1-866-300-1110.**

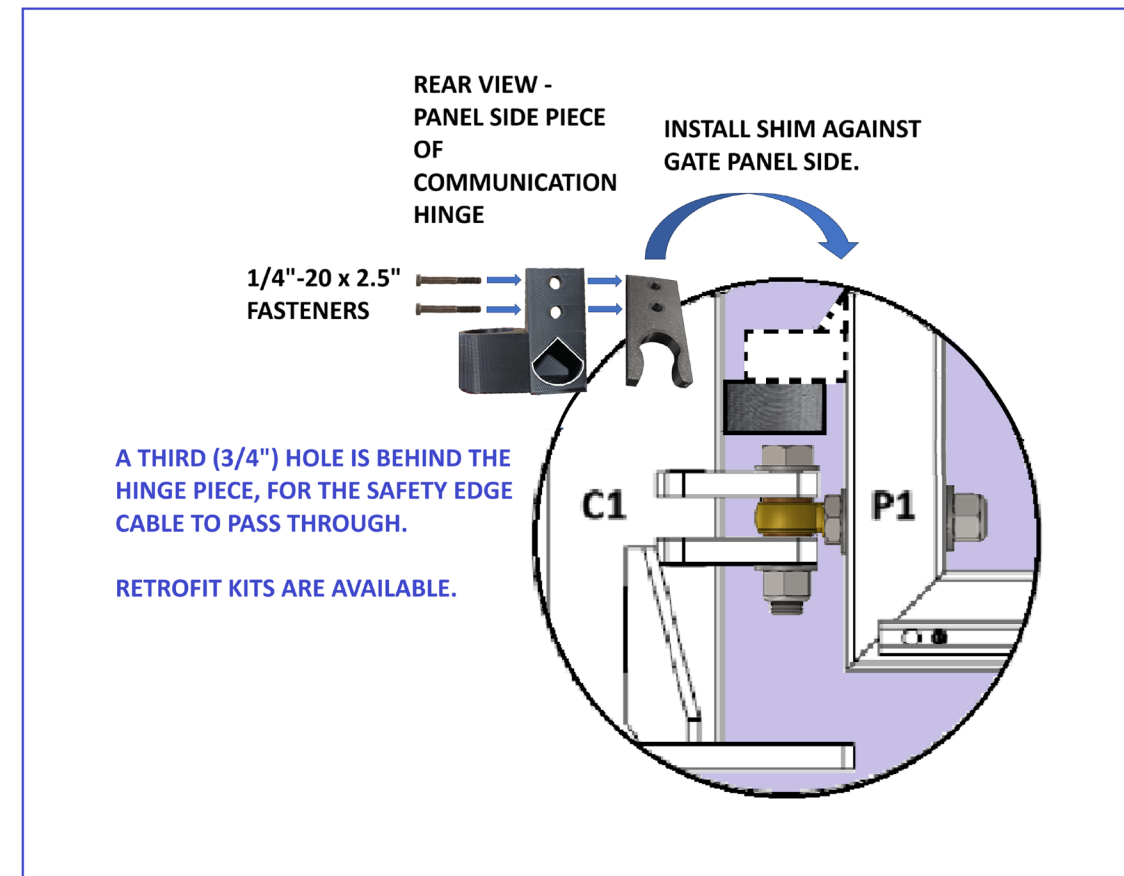

## STEP TWO (SPEEDGATE): Connecting the Sensing Edge Leads from Each Panel to the MIM-62 and Controller



**SAFETY WARNING:** Before you start, clear the gate travel area of all obstructions and persons. Restrict gate access.

### SPEEDGATE GATE MODELS

All SpeedGate safety inputs, except vehicle detector loop leads, terminate into the post termination box. The post termination box is located in the primary column, and 18-gauge multi-conductor low voltage cable connects the post termination box to the operator cabinet, via conduit. Current SpeedGate models include a second post termination box located in the secondary column, designed for mounting the second of two MIM-62 units. **Retrofits are possible only with assistance from WPS. If you are in need of a retrofit, call WPS Technical Support at 1-866-300-1110.**

In a dual gate configuration, which is the most common, there are two gate operators (primary and secondary) housed in one operator cabinet. The primary operator controls the gate motor in the column closest to the controllers. The secondary operator controls the gate motor in the column furthest from the controllers.

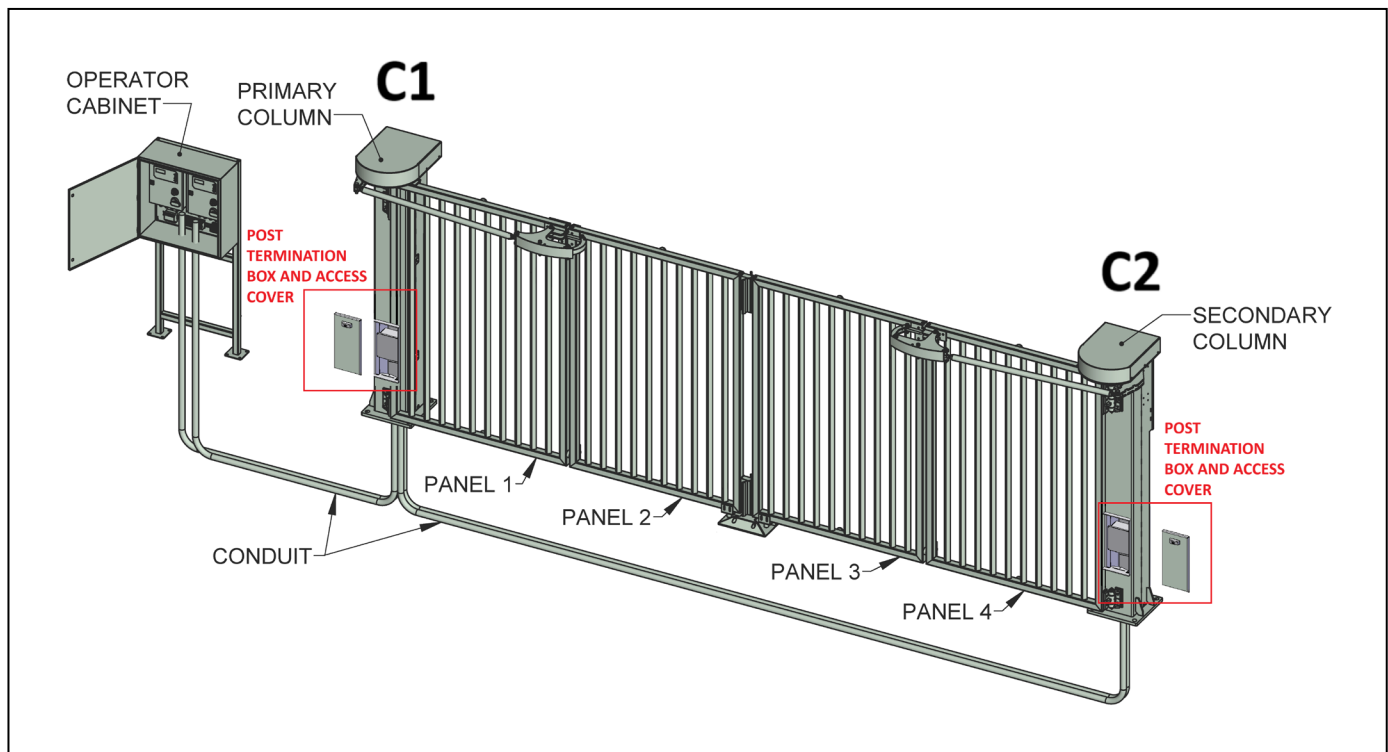

Current SpeedGate models provide a mounting location for one MIM-62 inside the lid of the post termination box in the primary column, with cable strain relief and additional terminal blocks. The secondary column only has a post-termination box for sensing edge connection. Additional cable is provided for running through conduit and connection to the Operator (controller).

- Each MIM-62 will accept up to 6 inputs (separate monitored devices) and connect them to either of two outputs for open and close directions. **WPS gates use the inputs for sensing edges only.**
- Your WPS gate operator monitors all external entrapment sensors connections by looking for NC contacts connected to input terminals.
- **MIM-62 Input Channels 1 and 2 must be used, and are always assigned to Output A.** The other input channels may be assigned to either Output A or Output B using the Input Assignment Switch on the rear panel. Use of all 6 inputs is not required.
- **Each of the Output circuits of MIM-62 should be set to “Relay” (normally closed) by the Output Type selection switch on the rear panel.**

### Install Module and Test

- A. CLOSE both gates. Turn OFF power from both operators. Turn OFF AC power at the source (circuit breaker panel) before accessing the wires in the SpeedGate junction boxes. Follow facility Lock Out/Tag Out procedures.

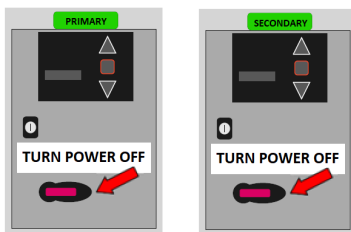

*The primary operator controls the gate motor in the column closest to the controllers. The secondary operator controls the gate motor in the column furthest from the controllers.*

- B. One MIM-62 will be mounted inside the lid of the post termination box (in the primary gate column). If already mounted, you will need to loosen the mounting slot screws and temporarily remove the unit(s), as the switches and the Learn button on the rear panel of MIM-62 must be accessed during installation. **Run the provided cable through conduit for connection to the Operators (controllers).**

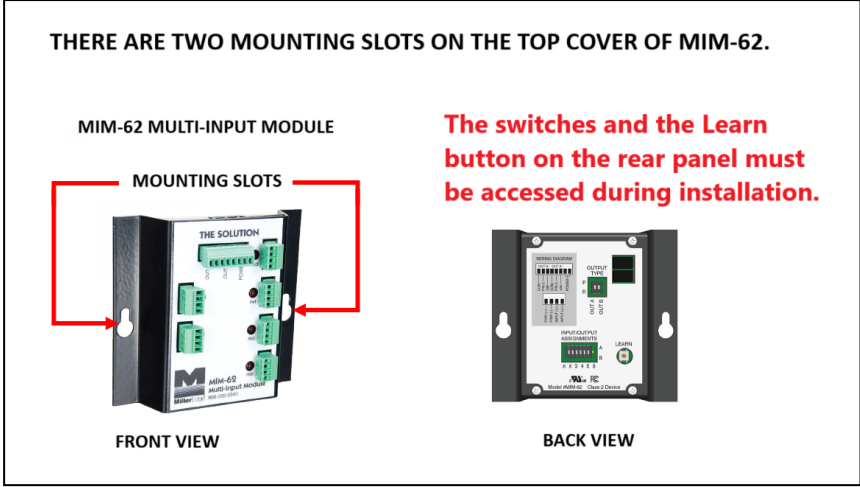

- C. Connect the sensing edge leads (Blue/Brown wires in heavy black jacketed sensing edge lead) from each panel to the MIM-62 in the post termination box for the primary operator, and the secondary operator, as applicable. Make sure sensing edge wiring is not pinched/kinked in at panel to column connection. **See connection diagrams following item I.**

Leave enough slack in your wiring to allow removal of MIM-62 if/when re-learning is required.

- D. When all sensing edge inputs are connected, **ENSURE NO ONE IS STANDING IN THE PATH OF THE GATE BECAUSE OPERATOR(S) WILL RECYCLE DURING START-UP.** Turn ON the power at the circuit breaker panel, and switch ON the operators. MIM-62 should display a brief light test followed by blinking of the Output A and Output B indicators. The Learn Mode LED on the rear panel will also be lit. This indicates that MIM-62 is in Learn Mode, and will display the present condition of each input channel’s sensor:

LED Status	Indication	Applicable to Wire Connections Herein (NC inputs at MIM-62 front and Relay outputs at MIM-62 rear)	Not Applicable
ON: solid	Open circuit (faulty wiring or nothing connected)	X	
BLINKING	10K ohm terminated sensor (no fault indicated)		X
OFF: solid	Normally Closed sensor (no fault indicated)	X	
FAST BLINK	Pulsed sensor (no fault indicated)		X

- E. If there is a fault, correct any wiring or make selection changes before proceeding.

**NOTE:** The LEDs behave differently in Learn Mode versus Run Mode.

- F. When all intended devices are connected and indicating no faults, momentarily press the Learn button on the rear panel. The lights should flash, and then all the LEDs should go OFF, except the green power LED. **Test each sensing edge to confirm the associated red LED turns ON when the device is activated.**
- G. MIM-62's should be operational and may be mounted to mounting location(s).
- H. **Troubleshooting the MIM-62**

If sensing edges are not functioning, check for proper power connections, including polarity, if necessary.

If, after the Learn button is pressed, one or both outputs are in fault (yellow LED ON), check to see which red LEDs are ON. Confirm the edge is connected to the assigned channel. If it is working, confirm the output of the edge is connected properly to the input connector.

If re-learning MIM-62 is necessary:

- a) Press the Learn button to clear settings.
- b) Press the Learn button to learn new settings.

**This means that after connections have been modified, pressing the Learn button twice will clear old settings, and activate the device to self-learn the new settings.**

**IMPORTANT:** Input Channels 1 and 2 must be used, and are always assigned to Output A. Otherwise, the MIM-62 will not “learn” new programming.

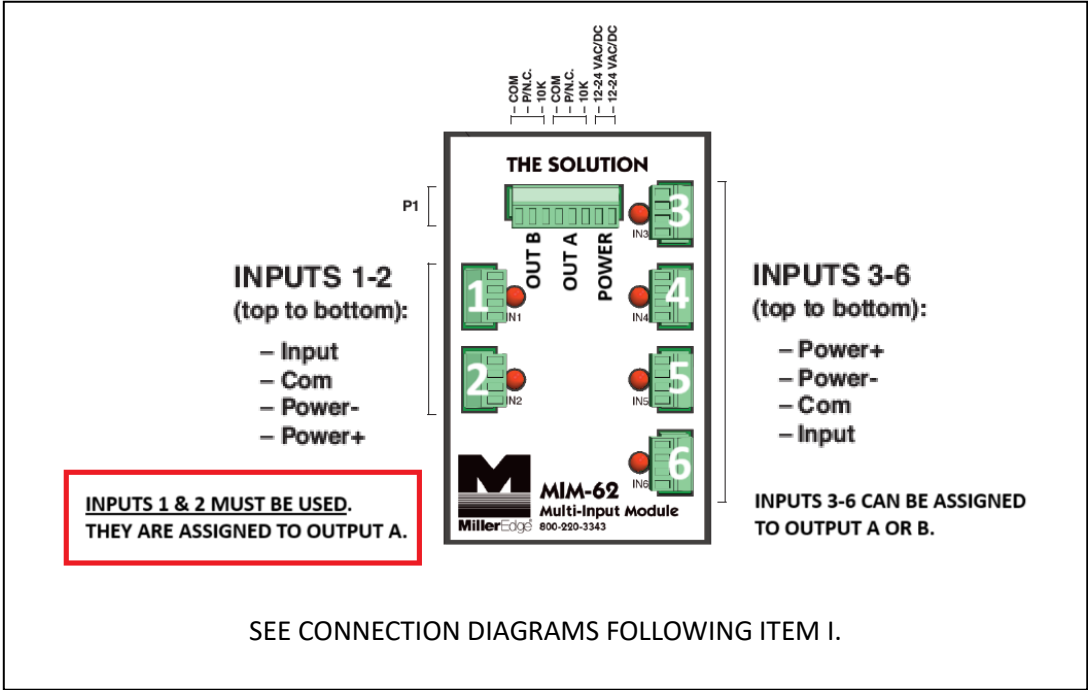

If all sensing edges and MIM-62 are working (**no red or yellow LEDs**), and the operator is still reporting a fault, check your wiring, and confirm MIM-62 outputs are connected properly to the operator’s inputs. Also, confirm the Output Interface is set correctly to ‘Relay,’ NOT ‘Pulsed’.

I. Location of Post Termination Boxes Housing MIM-62’s:

As shown in the illustration below, dual-folding gates include two posts (columns) with a total of four folding gate panels attached.

The C1 (P1 & P2) side is located at gate column 1, which is on the left-hand side (closest to the controller) and attaches to gate panels 1 and 2. One MIM-62 will be mounted inside the lid of the post termination box at C1 (the primary gate column).

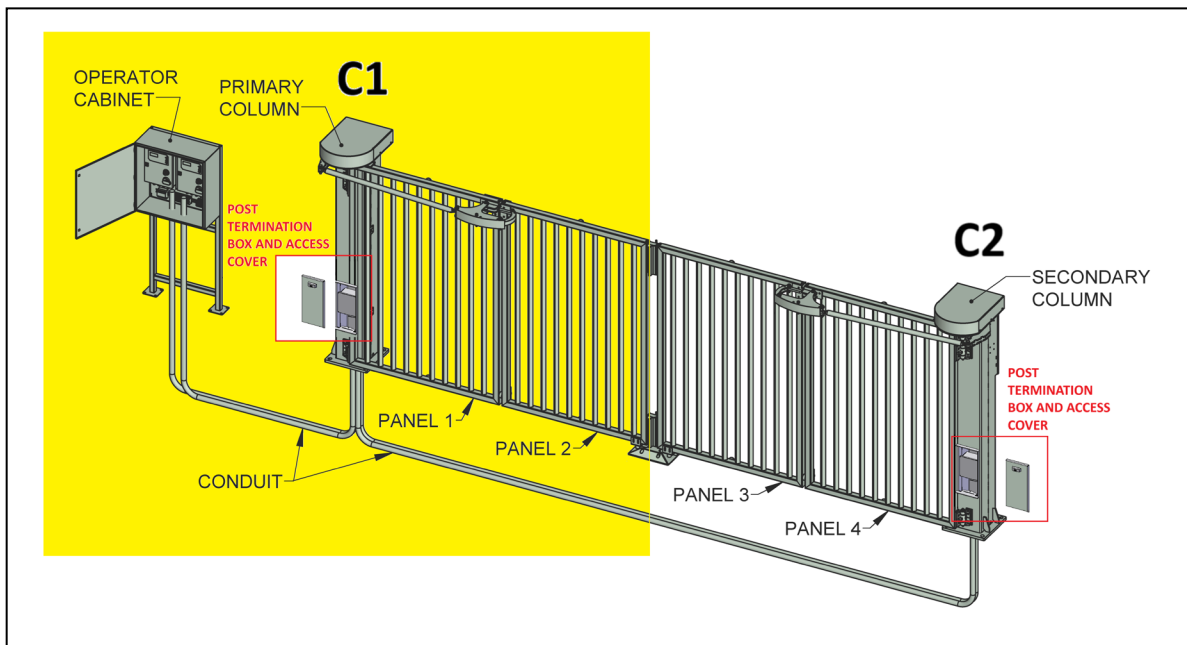

The C2 (P3 & P4) side is located at gate column 2, which is on the right-hand side and attaches to gate panels 3 and 4. It is a mirror image of the C1 side.

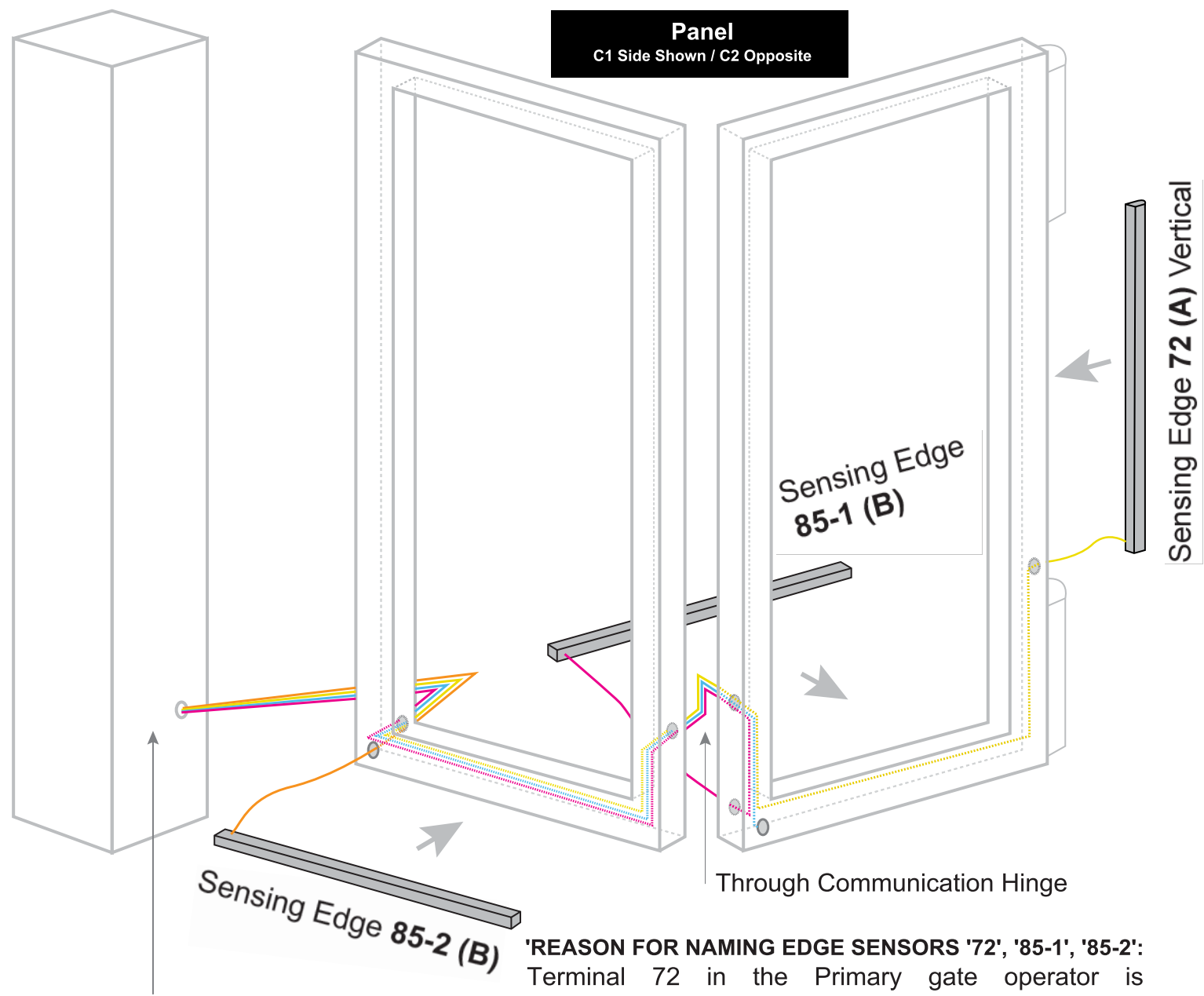

**SpeedGate Layout**

Column  
Through Communication Hinge/Cable Guard  
Terminate at MIM-62

**'REASON FOR NAMING EDGE SENSORS '72', '85-1', '85-2':**  
Terminal 72 in the Primary gate operator is programmed so the edge sensor will operate when the gate is moving in the CLOSE direction.

Terminal 85 in the Primary gate operator is programmed so the edge sensor will operate when the gate is moving in the OPEN direction.

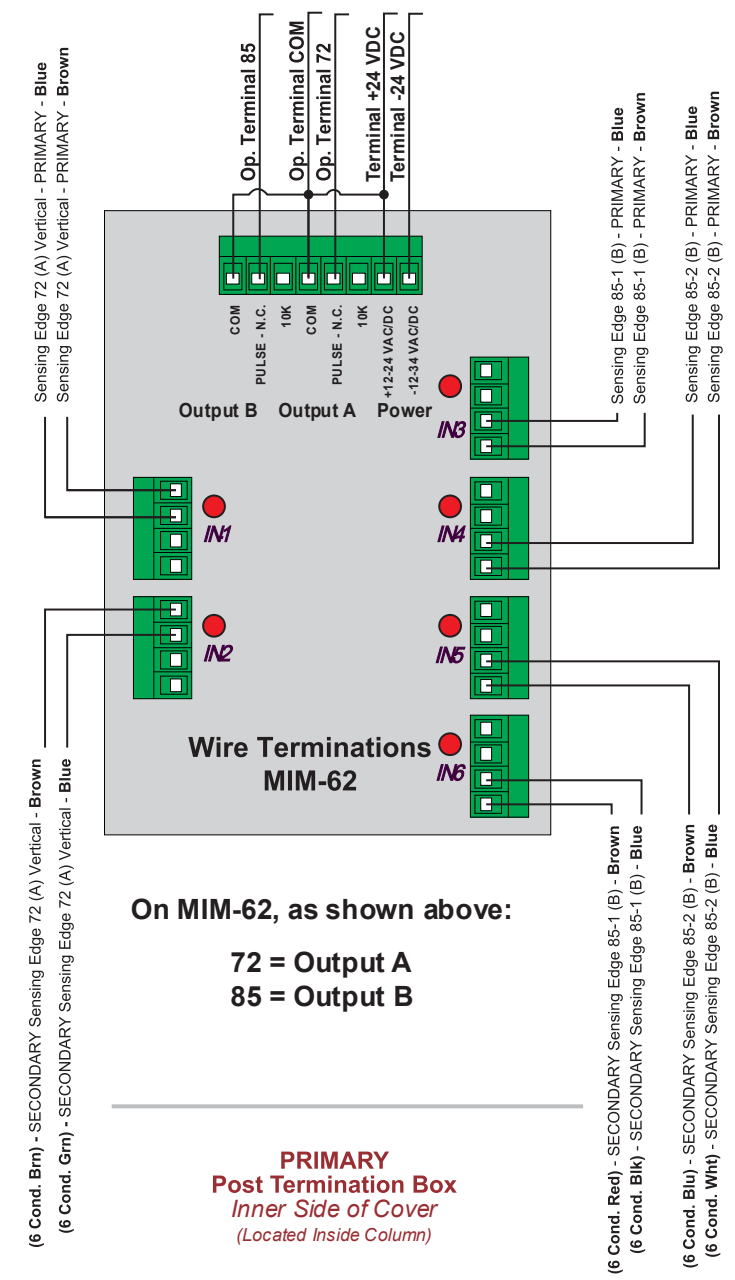

**Connection of Sensing Edge Leads from Each Panel to the MIM-62 on SpeedGate Models**

# 1 FIELD CONNECTIONS

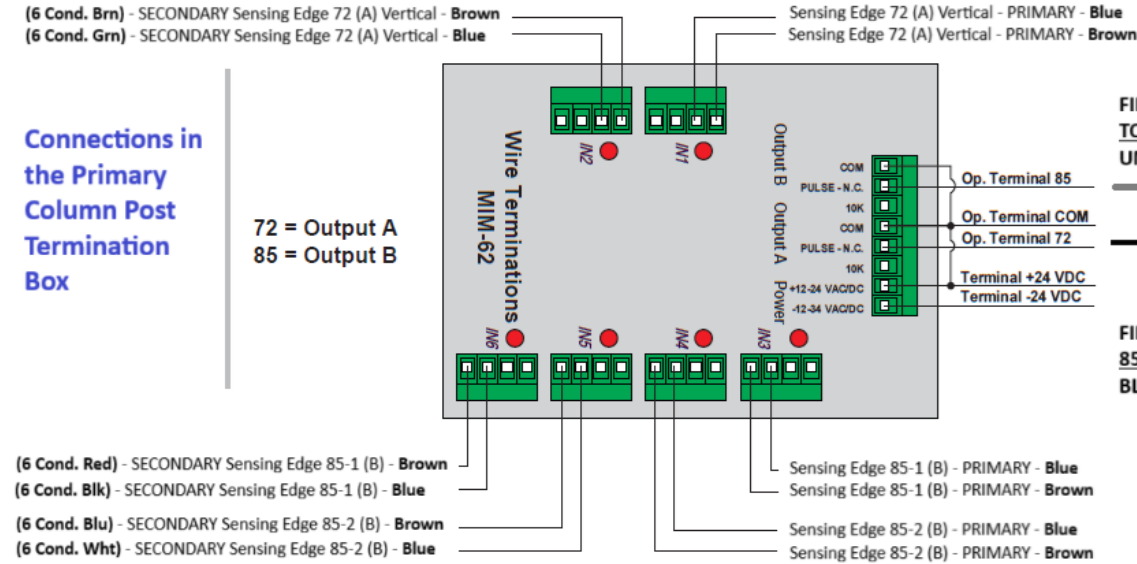

Connections in the Primary Column Post Termination Box

72 = Output A  
85 = Output B

IN THE FIELD, PLUG THESE TWO SAFETY EDGE OUTPUTS INTO THE GREEN TERMINAL BLOCKS [INSIDE THE OPERATOR CABINET ON THE ENCLOSURE TERMINAL STRIP (ETS) UNDERNEATH EACH OPERATOR]. THEY ARE FACTORY-CONNECTED TO TERMINAL 72 (INPUT FOR CLOSE DIRECTION OPERATION, AND TERMINAL 85 (INPUT FOR OPEN DIRECTION OPERATION).

FIELD-CONNECT MIM-62 O/P TERMINAL 72 TO TERMINAL 51 (GREEN TERMINAL BLOCK UNDERNEATH OPERATOR).



(4 Cond. Blk) Sensing Edge Output A  
(4 Cond. Wht) Sensing Edge Output B



Sensing Edge Output A) - PRIMARY - 72 & SECONDARY - 72  
Sensing Edge Output B) - PRIMARY - 85 & SECONDARY - 85

FIELD-CONNECT MIM-62 O/P TERMINAL 85 TO TERMINAL 52 (GREEN TERMINAL BLOCK UNDERNEATH OPERATOR).

## SpeedGate Safety Edge Inputs to MIM-62 Interface Module, and Operator

DIAGRAMS BELOW ARE PROVIDED FOR INFORMATION PURPOSES ONLY.

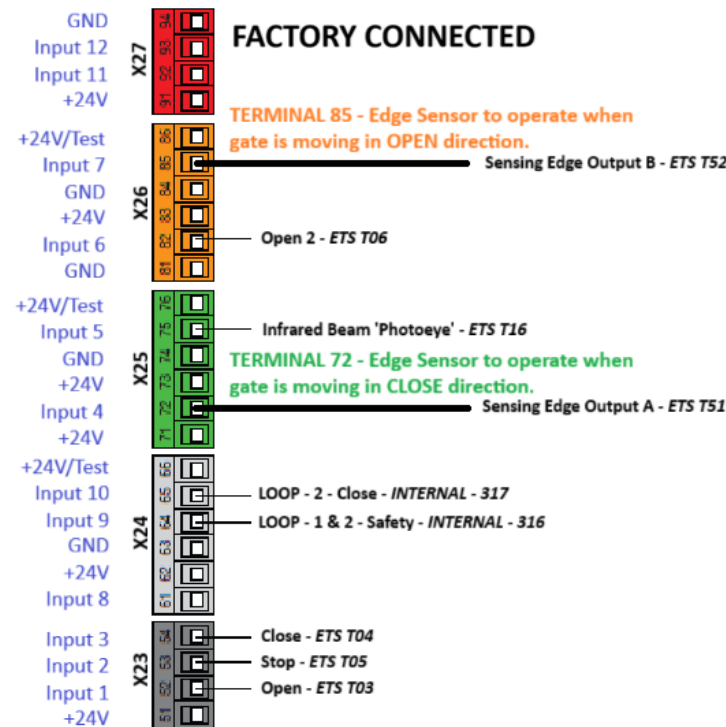

THESE ARE FACTORY-INSTALLED EDGE SENSOR CONNECTIONS TO THE PROCESSOR CIRCUIT BOARD IN THE PRIMARY OPERATOR TERMINAL BLOCK. **NO FIELD ACTION IS REQUIRED HERE.**  
SpeedGate controllers are currently factory programmed to use Edge Sensor terminal 72 input for CLOSE direction operation, and terminal 85 input for the OPEN direction. **DO NOT PERFORM FIELD PROGRAMMING OR RETROFITS ON AN EXISTING MODEL YOURSELF. CALL WPS TECHNICAL SUPPORT AT 1-866-300-1110.**

### Connections in the Secondary Column Post Termination Box



## 2 MIM-62 OUTPUT TYPE AND DIP SWITCH SETTINGS

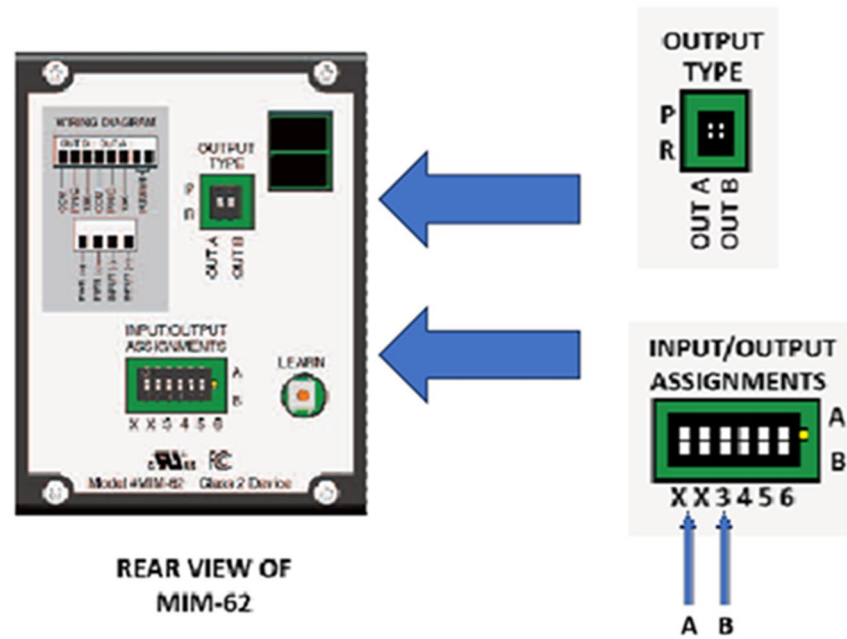

THESE ARE FACTORY SETTINGS, PROVIDED FOR REFERENCE.

INPUT CHANNELS 1 AND 2 ("XX") ARE HARD-WIRED FOR OUTPUT A. **OUTPUT A** WILL BE PROGRAMMED TO ACTIVATE THE SENSORS WHEN THE GATE IS **CLOSING**.

MIM-62 INPUTS	SENSING EDGE	Connect to MIM-62 WIRE COLOUR
IN1	72 (A) VERTICAL- PRIMARY	Blue
	72 (A) VERTICAL- PRIMARY	Brown
IN2	(6 Cond. Brn) - 72 (A) VERTICAL - SECONDARY	Brown
	(6 Cond. Grn) - 72 (A) VERTICAL - SECONDARY	Blue

SET THE DIP SWITCHES FOR INPUTS 3 TO 6 FOR OUTPUT B. **OUTPUT B** WILL BE PROGRAMMED TO ACTIVATE THE SENSORS WHEN THE GATE IS **OPENING**.

MIM-62 INPUTS	SENSING EDGE	Connect to MIM-62 WIRE COLOUR
IN3	85-1 (B) PRIMARY	Blue
	85-1 (B) PRIMARY	Brown
IN4	85-2 (B) PRIMARY	Blue
	85-2 (B) PRIMARY	Brown
IN5	(6 Cond. Blu) 85-2 (B) SECONDARY	Brown
	(6 Cond. Wht) 85-2 (B) SECONDARY	Blue
IN6	(6 Cond. Red) 85-1 (B) SECONDARY	Brown
	(6 Cond. Blk) 85-1 (B) SECONDARY	Blue

### SpeedGate: MIM-62 Interface Module Settings

## STEP TWO (FOLDSMART): Connecting the Sensing Edge Leads from Each Panel to the MIM-62 and Controller



**SAFETY WARNING:** Before you start, clear the gate travel area of all obstructions and persons. Restrict gate access.

### FOLDSMART GATE MODELS

Unlike SpeedGate models, FoldSmart gates do not have a post termination box for safety device inputs. In a double bi-fold configuration, which is the most common, there are two gate operators housed in separate control cabinets (illustrated below). Each control cabinet will require its own MIM-62 unit; i.e., a total of two (2). **Current FoldSmart models provide a mounting location for the MIM-62 inside the back of each control cabinet, next to the circuit board.**

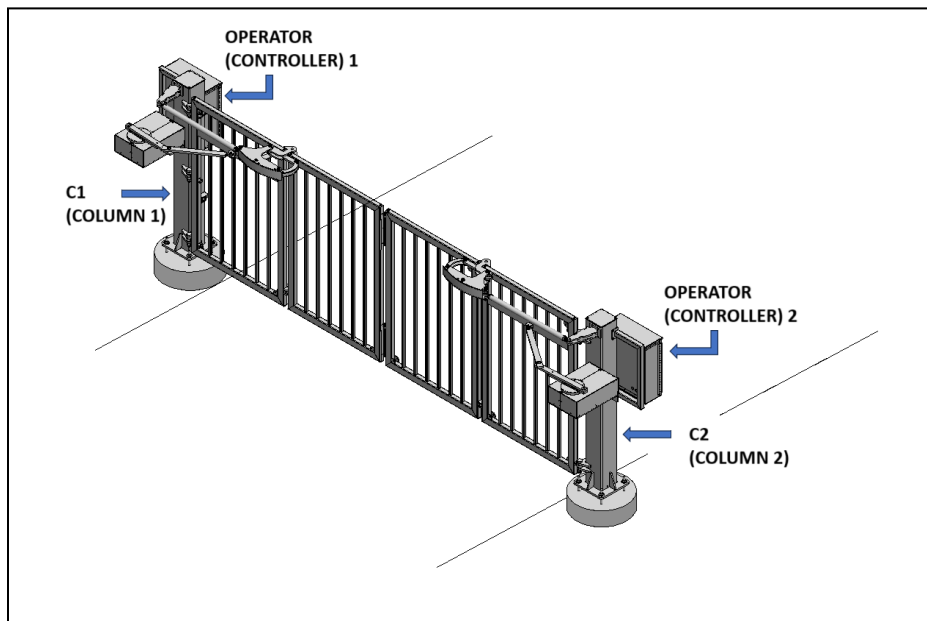

- Each MIM-62 will accept up to 6 inputs (separate monitored devices) and connect them to either of two outputs for open and close directions. **WPS gates use the inputs for sensing edges only.**
- Your WPS gate operator monitors all external entrapment sensors connections by looking for NC contacts connected to input terminals.

- **MIM-62 Input Channels 1 and 2 must be used, and are always assigned to Output A.** The other input channels may be assigned to either Output A or Output B using the Input Assignment Switch on the rear panel. Use of all 6 inputs is not required.
- **Each of the Output circuits of MIM-62 should be set to “Relay” (normally closed) by the Output Type selection switch on the rear panel.**

**Install Module and Test**

A. CLOSE both gates.  
 Turn OFF AC power at the source (circuit breaker panel) before accessing the wires in the FoldSmart junction box. Follow facility Lock Out/Tag Out procedures. Make sure both the DC and AC power switches, on the side of **both** (in a double bi-fold gate) FoldSmart control boxes, are in the **OFF** position.

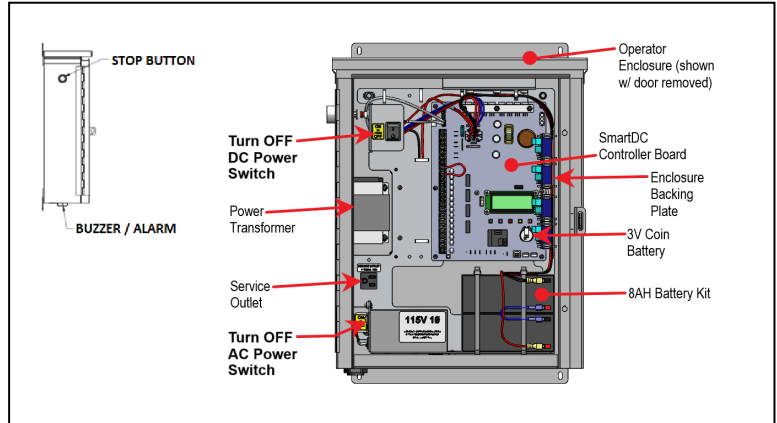

B. MIM-62 units will be mounted inside the back of each control cabinet, next to the circuit board. If already mounted, you will need to temporarily remove the unit(s), as the switches and the Learn button on the rear panel of MIM-62 must be accessed during installation.

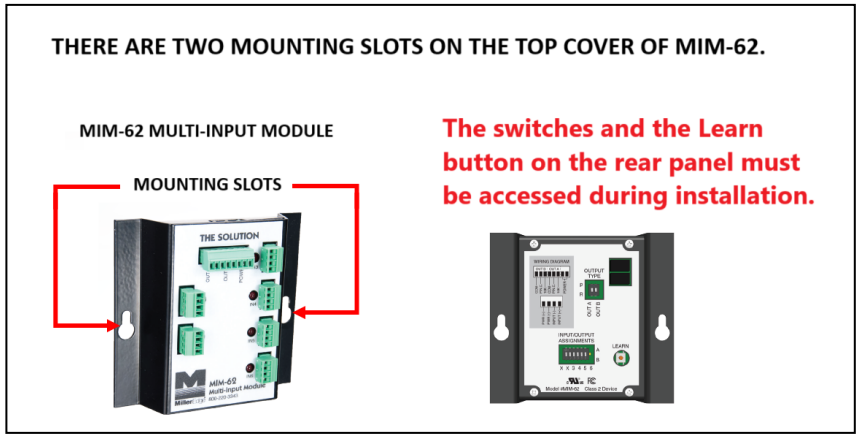

C. Connect the sensing edge leads (Blue/Brown wires in heavy black jacketed sensing edge lead) from each panel to the MIM-62 in proximity to the nearest operator control cabinet. Make sure that sensing edge wiring is not pinched/kinked in at panel to column connection. **See connection diagrams following item H.**

Leave enough slack in your wiring to allow removal of MIM-62 if/when re-learning is required.

- D. When all sensing edge inputs are connected to MIM-62's, **ENSURE NO ONE IS STANDING IN THE PATH OF THE GATE BECAUSE OPERATOR(S) WILL RECYCLE DURING START-UP.** Turn ON the power at the circuit breaker panel, and switch ON the operator AC and DC switches. MIM-62 should display a brief light test followed by blinking of the Output A and Output B indicators. The Learn Mode LED on the rear panel will also be lit. This indicates that MIM-62 is in Learn Mode, and will display the present condition of each input channel's sensor:

LED Status	Indication	Applicable to Wire Connections Herein (NC inputs at MIM-62 front and Relay outputs at MIM-62 rear)	Not Applicable
ON: solid	Open circuit (faulty wiring or nothing connected)	X	
BLINKING	10K ohm terminated sensor (no fault indicated)		X
OFF: solid	Normally Closed sensor (no fault indicated)	X	
FAST BLINK	Pulsed sensor (no fault indicated)		X

- E. If there is a fault, correct any wiring or make selection changes before proceeding.

**NOTE:** The LEDs behave differently in Learn Mode versus Run Mode.

- F. When all intended devices are connected and indicating no faults, momentarily press the Learn button on the rear panel. The lights should flash, and then all the LEDs should go OFF, except the green power LED. **Test each sensing edge to confirm the associated red LED turns ON when the device is activated.**

- G. MIM-62's should be operational and may be mounted to mounting location(s).

**H. Troubleshooting the MIM-62**

If sensing edges are not functioning, check for proper power connections, including polarity, if necessary.

If, after the Learn button is pressed, one or both outputs are in fault (yellow LED ON), check to see which red LEDs are ON. Confirm the edge is connected to the assigned channel. If it is working, confirm the output of the edge is connected properly to the input connector.

If re-learning MIM-62 is necessary:

- a) Press the Learn button to clear settings.
- b) Press the Learn button to learn new settings.

This means that after connections have been modified, pressing the Learn button twice will clear old settings, and activate the device to self-learn the new settings.

**IMPORTANT:** Input Channels 1 and 2 must be used, and are always assigned to Output A. Otherwise, the MIM-62 will not “learn” new programming.

If all sensing edges and MIM-62's are working (**no red or yellow LEDs**), and an operator is still reporting a fault, check your wiring, and confirm MIM-62 outputs are connected properly to the operator's inputs. Also, confirm the Output Interface is set correctly to 'Relay,' NOT 'Pulsed'.

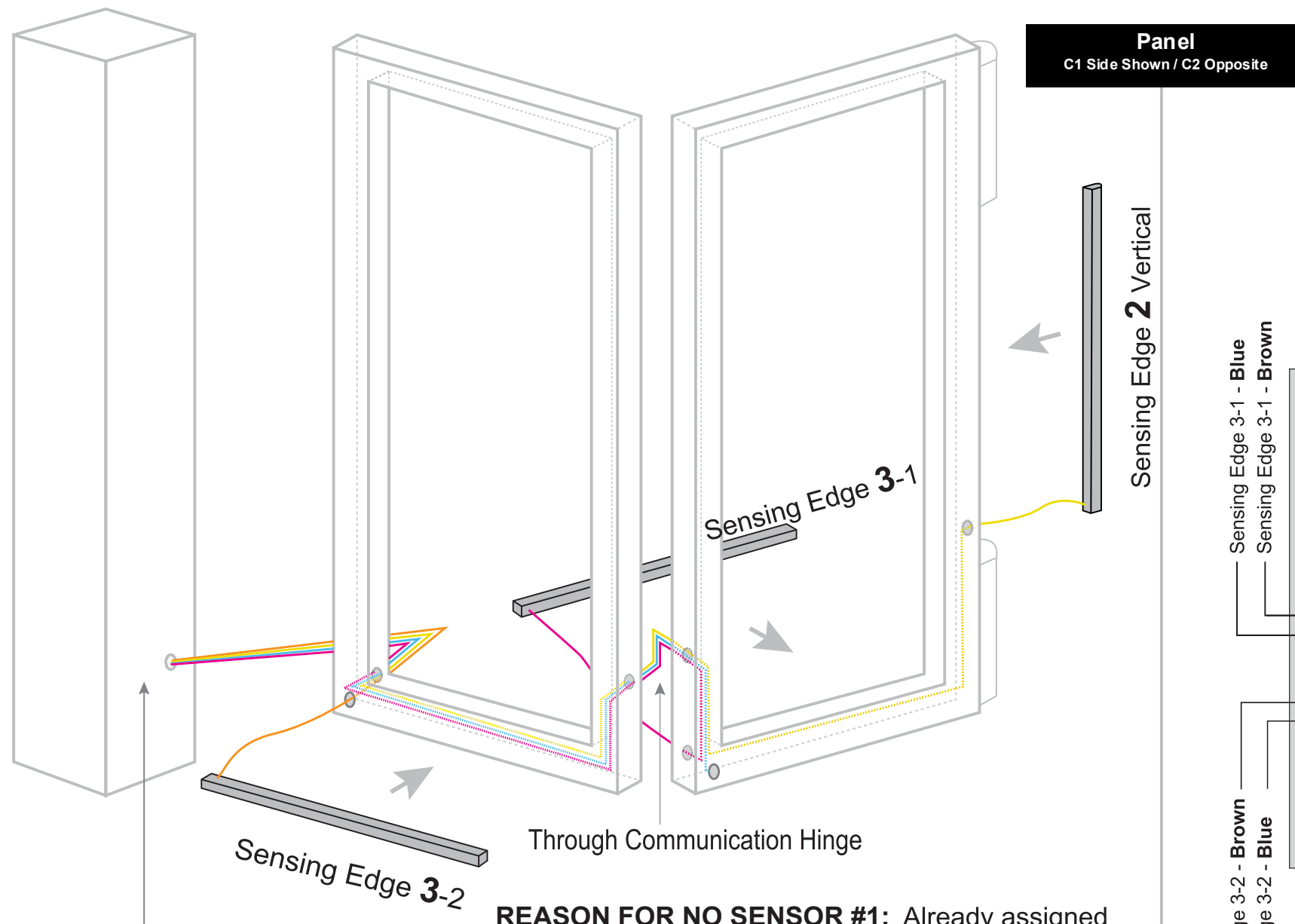

Column  
Through Communication Hinge/Cable Guard  
**Terminate at MIM-62**  
**FoldSmart Layout**

**REASON FOR NO SENSOR #1:** Already assigned to photo eye gate operator inputs.

**AT THE GATE OPERATOR:** 1 vertical edge (Sensor 2) should be programmed EDGE CLOSE. 2 horizontal edges (Sensor 3) should be programmed EDGE OPEN.

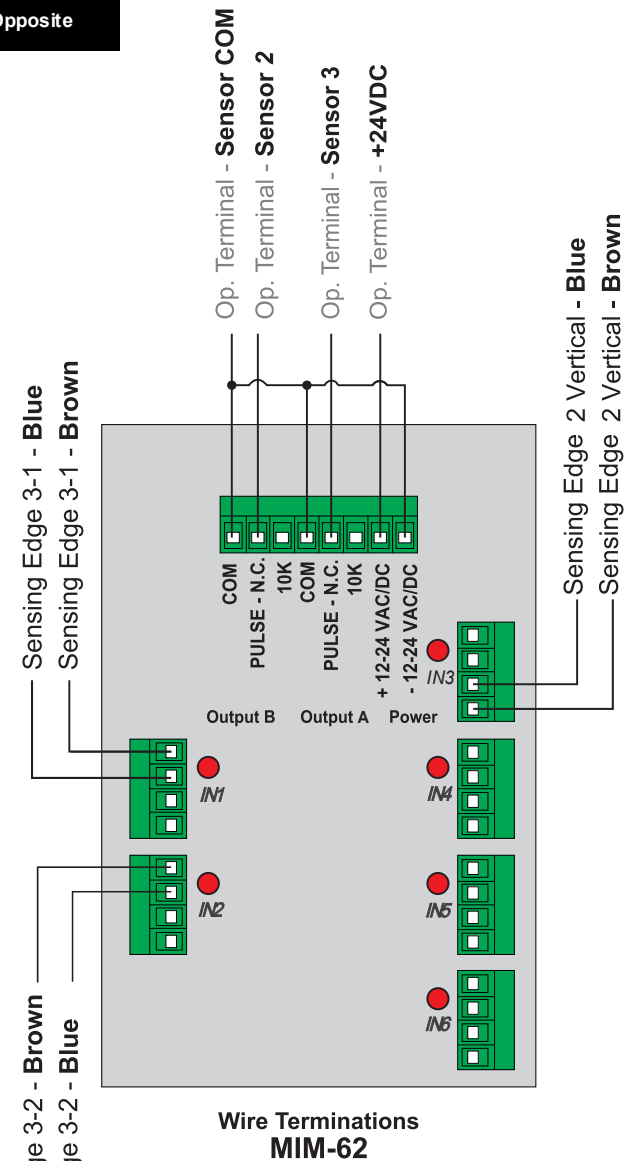

**Wire Terminations MIM-62**  
**FSXT Operator**  
Programming:  
Sensor 2 can be set to Edge Close  
Sensor 3 can be set to Edge Open

THESE CONNECTIONS ARE TO THE CONTROLLER NEAR THE C1 (COLUMN 1) SIDE OF THE GATE.

MAKE THE SAME CONNECTIONS TO THE CONTROLLER NEAR THE C2 SIDE OF THE GATE.

Connection of Sensing Edge Leads from Each Panel to the MIM-62 on FoldSmart Gate Models

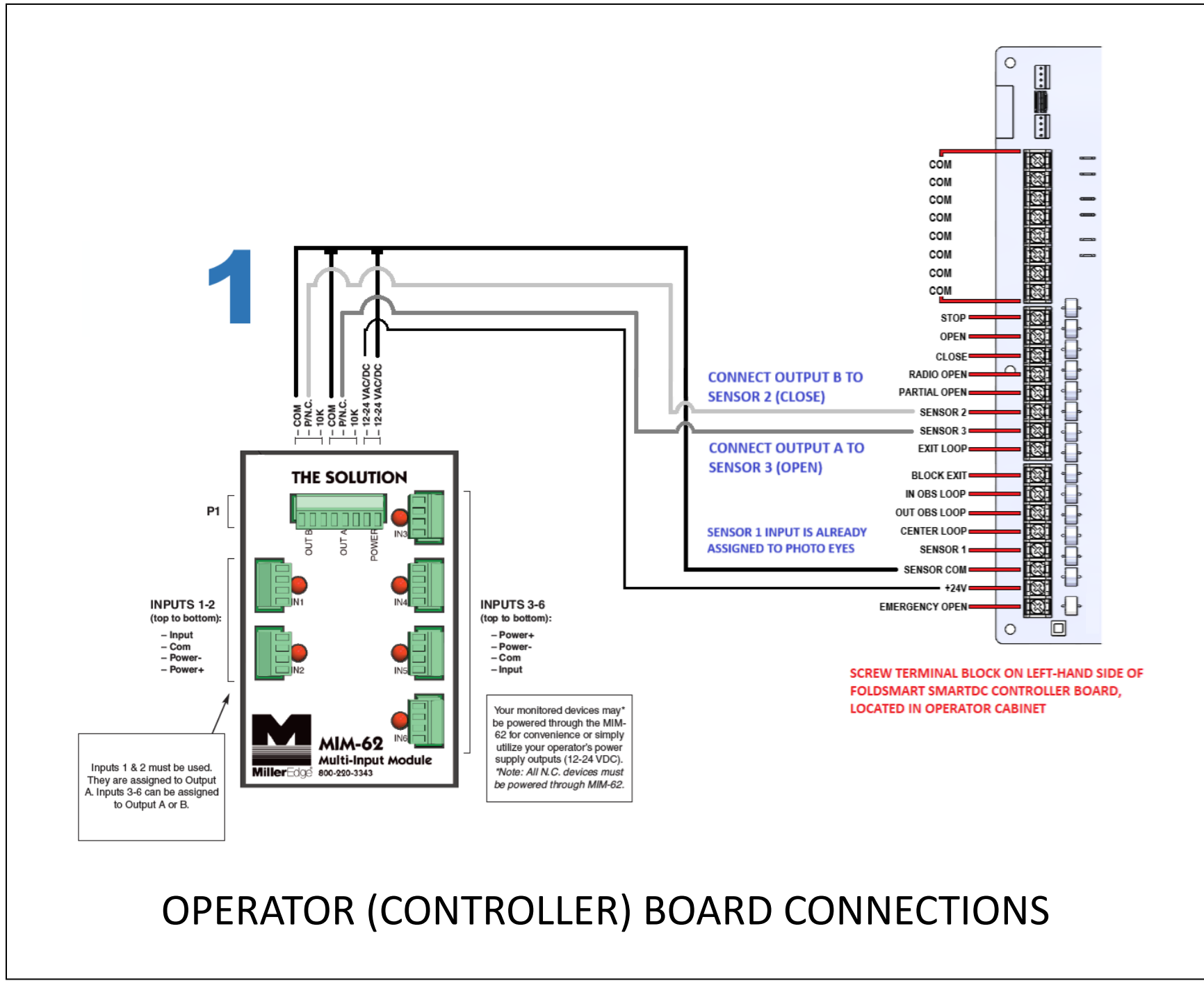

MAKE THE SAME CONNECTIONS FROM THE MIM-62 TO THE CONTROLLER ON THE OTHER SIDE OF THE GATE.

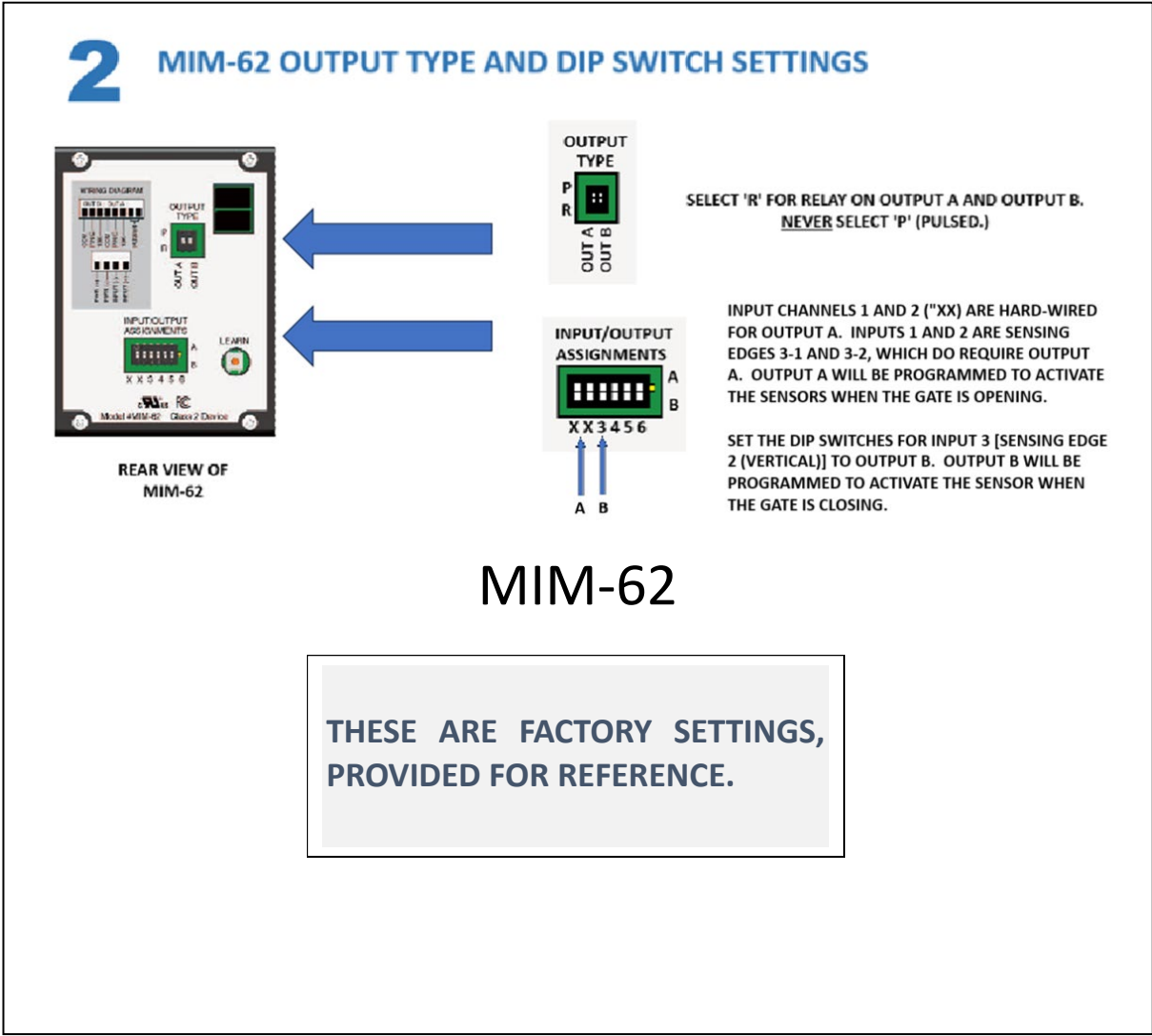

Connection of MIM-62 to Controller on FoldSmart Gate Models

## STEP THREE (SPEEDGATE): Programming the Operator (Controller) Installer Menu to Accept Sensing Edge Inputs

### SPEEDGATE GATE MODELS

SpeedGate controllers are currently factory programmed to use sensing edge terminal 72 input for CLOSE direction operation, and terminal 85 input for the OPEN direction. **DO NOT PERFORM FIELD PROGRAMMING OR RETROFITS ON AN EXISTING MODEL YOURSELF. CALL WPS TECHNICAL SUPPORT AT 1-866-300-1110.**

*FoldSmart operator programming instructions commence on next page.*

### STEP THREE (FOLDSMART): Programming the Operator (Controller) Installer Menu to Accept Sensing Edge Inputs

#### FOLDSMART GATE MODELS

Summary of How to Navigate Functions while in Menu Mode			
To change data appearing on the display:	To navigate through the selections:	To accept what appears on the display:	To navigate between menu items:
Press SELECT.	Press NEXT or PREVIOUS.	Press SELECT.	Press NEXT or PREVIOUS.
Pressing SELECT causes the upper two characters to blink, which indicates the display is ready to accept changes to a menu setting.	Pressing PREV moves to the previous menu selection.  Pressing NEXT advances through the next available menu selection.	Two blinking characters indicate that the display will accept changes.  Pressing SELECT a second time accepts what appears on the display. The entry mode is complete when the two characters stop blinking.	Pressing NEXT advances through the next available menu selection.  Pressing PREV moves to the previous menu selection.
Pressing MENU returns to Run Mode and a gate status display appears.			
NOTE: <i>The MENU button does not function while the selection is still blinking.</i>			
Pressing RESET clears faults and returns to Run Mode. A gate status display appears.			
NOTE: <i>The RESET button cannot be used to exit Menu Mode.</i>			

To access the Installer menu and configure sensor inputs, take the following steps in both Operators, completing one at a time (in a double bi-fold gate system).

The operator must be in Run Mode with a gate status showing on the display. The motor cannot be engaged and the gate cannot be moving.

1. Start at a gate status display. To bypass the Operator Status Displays, press the **MENU** button twice.

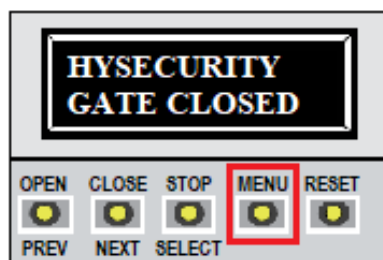

**X2**

The **CLOSE TIMER** display appears indicating you have accessed the User Menu.

- To access the Installer Menu, simultaneously press **OPEN** and **RESET**.

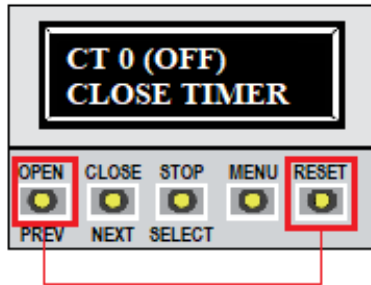

Release the buttons and the **USAGE CLASS** display appears indicating entrance to the Installer Menu. The USAGE CLASS display is the first item in the Installer Menu.

- Press **NEXT** to navigate to the desired **SENSOR** display.

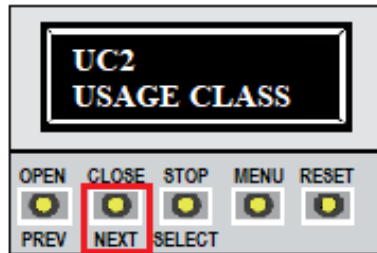

- When the desired sensor type is shown on the screen press **SELECT**. There are three programmable sensor inputs available, depending upon whether the sensing edge has been wired to Sensor input 1, 2 or 3 on the FoldSmart controller circuit board. These are for configuring UL 325 compliant sensor input settings for external entrapment protection sensor monitoring.

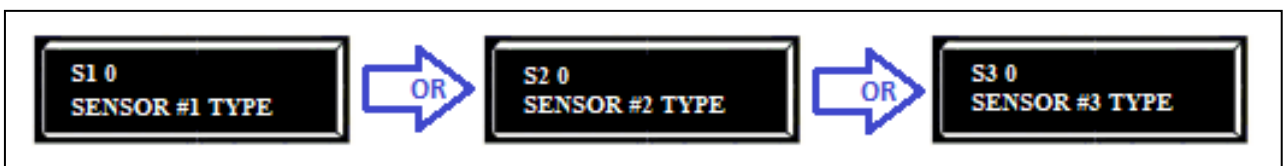

One vertical edge should be programmed **EDGE CLOSE** (setting option 3).

Two horizontal edges should be programmed **EDGE OPEN** (setting option 5).

If you have wired sensing edges to Sensor 2 and Sensor 3 inputs on the FoldSmart controller board as shown in Connection of MIM-62 to Controller on FoldSmart Gate Models, you will now:

- a) Program Sensor 2 (vertical) to EDGE CLOSE so the sensing edge will only operate when the gate is moving in the close direction.
- b) Program Sensor 3 (the 2 horizontal sections) to EDGE OPEN so the sensing edge will only operate when the gate is moving in the open direction.

**NOTE:**

After following instructions 'A' and 'B' below, it is recommended to review the information in:

- C. [Program Unused Sensor Inputs to NOT USED](#); and
- D. [Supplementary Programming Information: Gate Edge Logic and Outputs](#)

**A. Program Sensor 2 (vertical) to EDGE CLOSE (setting option 3) so the sensing edge will only operate when the gate is moving in the close direction:**

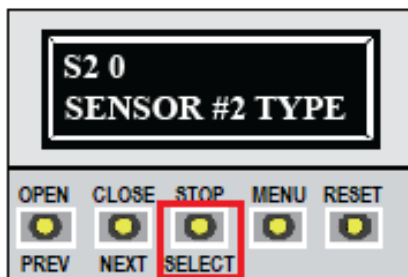

A-1 In the above example, Sensor 2 input has been selected. This selection is made when the sensing edge has been wired to the Sensor 2 input on the FoldSmart controller board. **After pressing SELECT, S2 will begin flashing, indicating readiness to be programmed.**

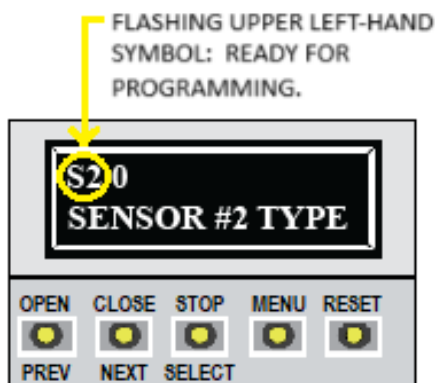

A-2 Press **NEXT** until **S2 = 3 = (EDGE CLOSE)**.



A-3 Enable **EDGE CLOSE** by pressing **SELECT** to choose (symbol flashes), and **SELECT** again (symbol stops flashing).

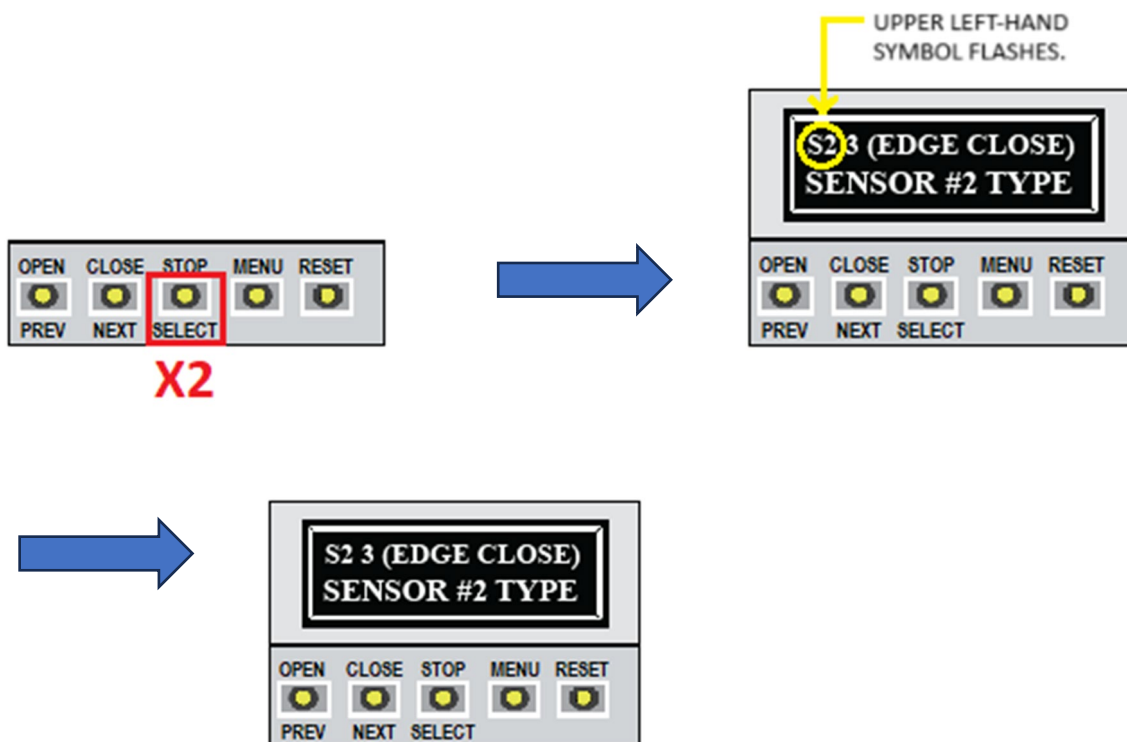

EDGE CLOSE means the sensing edge will only operate when the gate is moving in the close direction. With this input enabled, when the edge comes into physical contact with an obstruction while the gate is CLOSING, the gate will either:

- Reverse to a fully open position (default setting) OR
- Reverse for 2 seconds, if the user has programmed the edge to do this\*.

\*Refer to NOTE 1: GATE EDGE LOGIC on page 34.

B. Program Sensor 3 (2 horizontal sections) to EDGE OPEN (setting option 5) so the sensing edge will only operate when the gate is moving in the open direction:

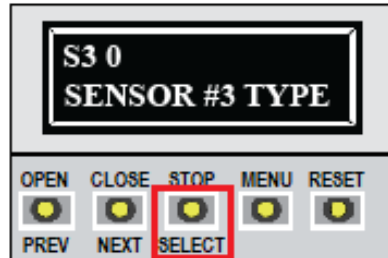

B-1 In the above example, Sensor 3 input has been selected. This selection is made when the sensing edge has been wired to the Sensor 3 input on the FoldSmart controller board. **After pressing SELECT, S3 will begin flashing, indicating readiness to be programmed.**

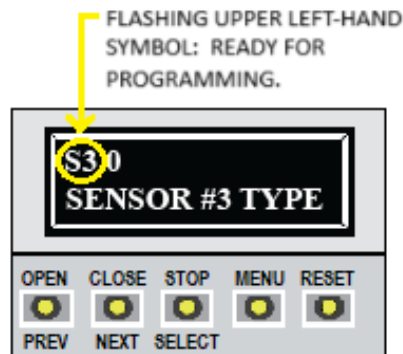

B-2 Press NEXT until S3 = 5 = (EDGE OPEN).

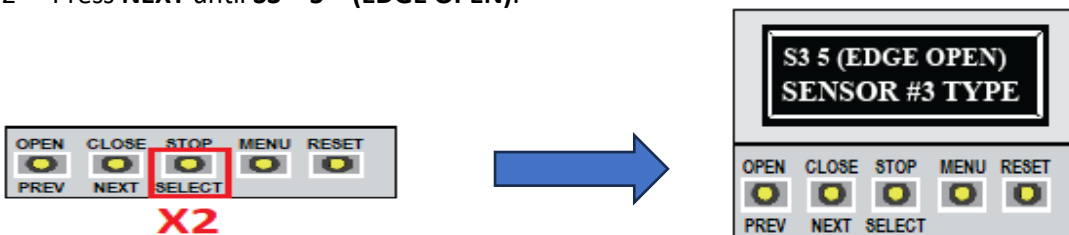

B-3 Enable **EDGE OPEN** by pressing **SELECT** to choose (symbol flashes), and **SELECT** again (symbol stops flashing).

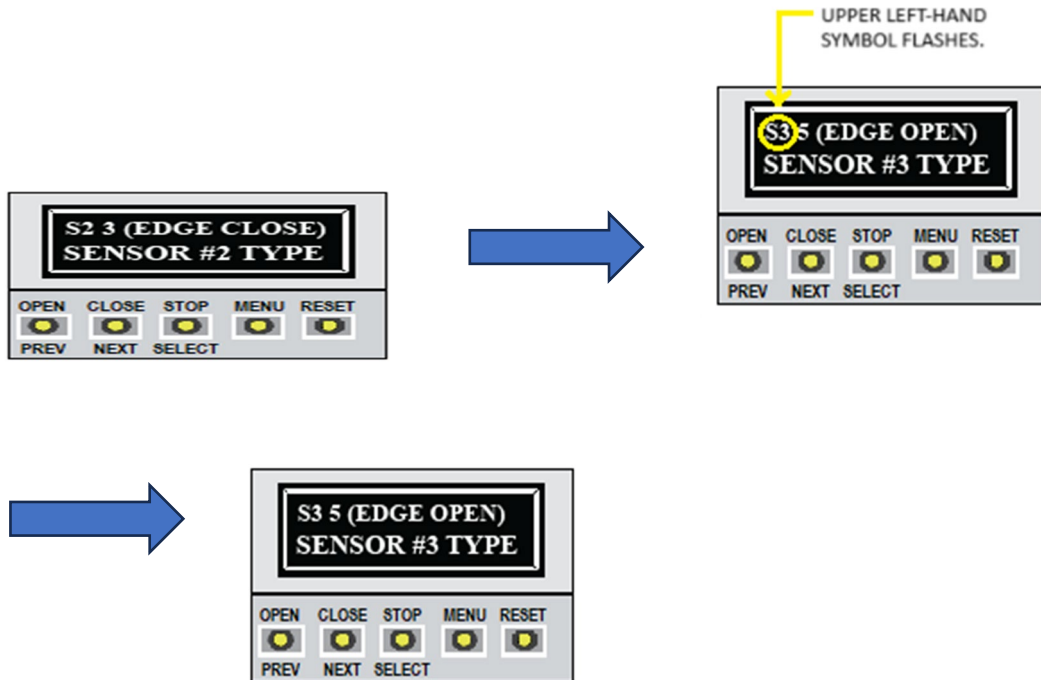

EDGE OPEN means the sensing edge will only operate when the gate is moving in the open direction. With this input enabled, when the edge comes into physical contact with an obstruction while the gate is OPENING, the gate will either:

- Reverse to a fully closed position (default setting) OR
- Reverse for 2 seconds, if the user has programmed the edge to do this\*.

\*Refer to NOTE 1: GATE EDGE LOGIC on page 34.

C. Program Unused Sensor Inputs to NOT USED

Sensing edges must be programmed to a non-zero number when initial configuration is performed. If a sensor input is intended not to be used, it must be programmed to NOT USED (see Setting Options table). The three programmable sensor inputs are labeled Sensor 1, Sensor 2, and Sensor 3 and are configurable in the installer menu (S1, S2, or S3) for the following options.

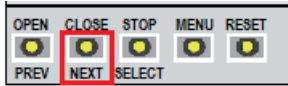

Press **NEXT** to navigate through the Sensor setting options shown below.

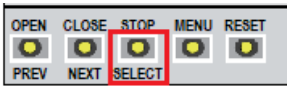

Press **SELECT** to choose (symbol flashes), and **SELECT** again (symbol stops flashing) to enable your desired setting option.

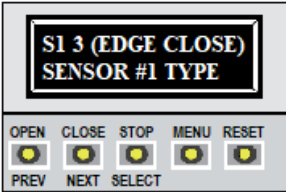
SETTING OPTIONS (Zero = Factory Setting)	What it Means	
0 = disabled	Factory setting; press <b>NEXT</b> , then press <b>SELECT</b> to choose and enable the setting option that applies ( <b>1, 3, 5 or 6</b> ).	
<b>1 = (NOT USED)</b>	If a sensor input is intended not to be used, it must be configured to <b>NOT USED</b> on the appropriate Sensor # within the installer menu.	
2 = (EYE CLOSE)	This setting applies to a photo eye sensor, not to a sensing edge.	
<b>3 = (EDGE CLOSE)</b>	 <p>Press <b>SELECT</b> to choose (symbol flashes), and <b>SELECT</b> again (symbol stops flashing) if you want to enable <b>EDGE CLOSE</b>.</p>	<p><b>EDGE CLOSE</b> means the sensing edge will only operate when the gate is moving in the close direction.</p> <p>If this input is enabled, when the edge comes into physical contact with an obstruction while the gate is <b>CLOSING</b>, the gate will either:</p> <ul style="list-style-type: none"> <li>• <b>Reverse to a fully open position (default setting) OR</b></li> <li>• Reverse for 2 seconds, if the user has programmed the edge to do this*.</li> </ul> <p>*Refer to NOTE 1: GATE EDGE LOGIC on page 34.</p>

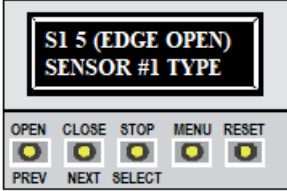
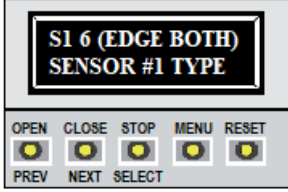
SETTING OPTIONS (Zero = Factory Setting)	What it Means	
4 = (EYE OPEN)	This setting applies to a photo eye sensor, not to a sensing edge.	
5 = (EDGE OPEN)	 <p>Press SELECT to choose (symbol flashes), and SELECT again (symbol stops flashing) if you want to enable EDGE OPEN.</p>	<p>EDGE OPEN means the sensing edge will only operate when the gate is moving in the open direction.</p> <p>If this input is enabled, when the edge comes into physical contact with an obstruction while the gate is OPENING, the gate will either:</p> <ul style="list-style-type: none"> <li>• <b>Reverse to a fully closed position (default setting) OR</b></li> <li>• Reverse for 2 seconds, if the user has programmed the edge to do this*.</li> </ul> <p>*Refer to NOTE 1: GATE EDGE LOGIC on page 34.</p>
6 = (EDGE BOTH)	 <p>Press SELECT to choose (symbol flashes), and SELECT again (symbol stops flashing) if you want to enable EDGE BOTH.</p>	<p>EDGE BOTH means the sensing edge will operate when the gate is moving in either the close direction or the open direction.</p> <ul style="list-style-type: none"> <li>• If this input is enabled, when the edge comes into physical contact with an obstruction while the gate is CLOSING the gate will reverse to a fully open position or reverse for two seconds, subject to how it is programmed.*</li> <li>• If this input is enabled, when the edge comes into physical contact with an obstruction while the gate is OPENING the gate will reverse to a fully closed position or reverse for two seconds, subject to how it is programmed.*</li> </ul> <p>*Refer to NOTE 1: GATE EDGE LOGIC on page 34.</p>
7 = (EYE BOTH)	This setting applies to a photo eye sensor, not to a sensing edge.	

**D. Supplementary Programming Information: Gate Edge Logic and Outputs**

The following NOTES provide supplementary programming information.

**NOTE 1:  
GATE EDGE LOGIC**

To access the GATE EDGE LOGIC function, press NEXT while you are still in the Installer menu and the display is not flashing, until you reach the GATE EDGE LOGIC display.

Press SELECT to choose (symbol flashes), and SELECT again (symbol stops flashing) if you want to enable the default setting of zero.

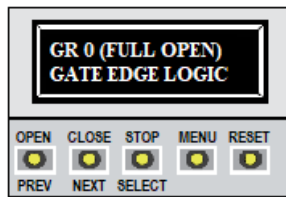

Press SELECT, then NEXT if you want to reach the optional setting of 1 (2-second reversal). Press SELECT if you want to enable setting 1.

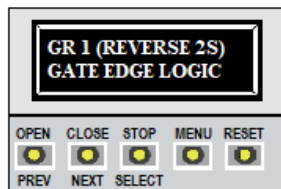

How the Gate Edge Logic function affects EDGE CLOSE, EDGE OPEN and EDGE BOTH behaviour when an obstruction comes into contact with the sensing edge:

If set to zero:

**0 = the GATE EDGE LOGIC default setting**

(Full open reversal for EDGE CLOSE, full close reversal for EDGE OPEN, and a full reversal whether opening or closing for EDGE BOTH).

If set to one:

1 = 2s reversal only

(An optional setting which causes the gate to reverse for 2 seconds if triggered. When choosing response to a sensing edge input, consider site set-up and anticipated traffic flow conditions).

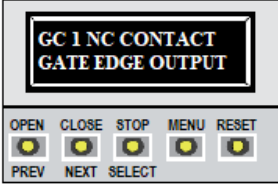
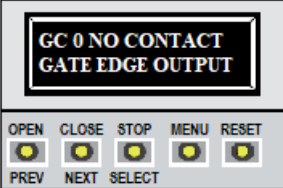
<p><b>NOTE 2: GATE EDGE OUTPUT</b></p> <p>To access the GATE EDGE OUTPUT function, press NEXT while you are still in the Installer menu and the display is not flashing, until you reach the GATE EDGE OUTPUT display.</p>	<p>Press SELECT to choose (symbol flashes), and SELECT again (symbol stops flashing) if you want to enable the default setting of 1.</p>  <p>Press SELECT, then NEXT if you want to reach the optional setting of 0 (Normally Open Edge).</p>  <p>Press SELECT if you want to enable setting 0.</p>	<p>This menu item only appears when USAGE CLASS is set to 4 (guarded industrial locations).</p> <p>Default setting of 1 = sensing edge with Normally Closed (NC) output.</p> <p>Optional setting of 0 requires a Normally Open (NO) output.</p>
--	--	---

### E: Exit the Installer Menu

Exit the Installer menu at the operator by pressing the MENU button.



The gate status appears in the display (GATE OPEN, GATE CLOSED or GATE STOPPED) indicating you have returned to operator Run Mode.

## STEP FOUR: Perform Sensing Edge Gate Tests

Confirm that each sensing edge stops and/or reverses as programmed. Test by placing a rigid obstruction in the path of the gate travel (OPEN and CLOSE) so the sensing edge(s) will make contact.

The gate should react as programmed upon contact with the obstruction. If it does not, troubleshoot to ensure sensing edges function as programmed. Upon resolution of any issues, advise the user of the gate to be certain to retest this vital function weekly.



The gate pathway and surrounding areas should be checked for obstructions and confirmed all-clear before operation is resumed.



If further assistance is required, please contact WPS Technical Support at 1-866-300-1110.